

Electrical battery with thermostat for heat recovery from 1000 to 4000 m³/h

- cod. ACC400005 - cod. ACC400006 - cod. ACC400007
- cod. ACC400008 - cod. ACC400009



DESCRIPTION

Electrical battery with thermostat for heat recovery from 1000 to 4000 m³/h with wire heating element mounted on a galvanised metal sheet duct.

The battery is complete with:

- automatic reset thermal protector (55°C) and manual reset thermal protector (85°C)
- relay/contactor and terminal board;
- adjustable duct thermostat -30+30°C

The battery is equipped with safety thermostats with automatic and manual reset, calibrated to trip in the event of failure or poor ventilation.

The heater has an auxiliary contact, which allows the remote control of the heating element through a dry contact deriving from an external switch or an ambient thermostat.

The adjustable bulb thermostat -30+30°C installed at the inlet, allows the activation temperature of the heating element to be set. The device is activated automatically when the set temperature is reached.

To prevent overheating of the battery, air flow must always be greater than the minimum flow rate indicated in the table

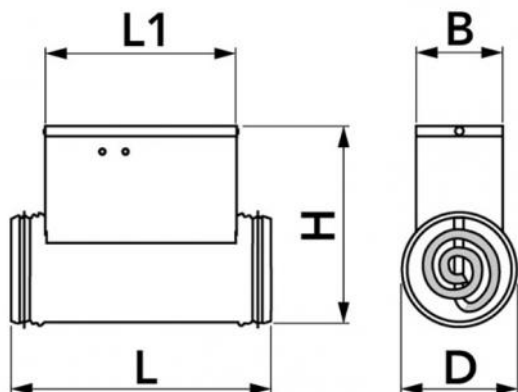

DIMENSIONS

CODE	L [mm]	H [mm]	B [mm]	L1 [mm]
ACC400005	400	450	200	300
ACC400006	400	450	200	300
ACC400007	400	490	210	300
ACC400008	400	495	260	300
ACC400009	400	550	260	300

TECHNICAL DATA

CODE	MODEL	NOMINAL FLOW RATE [m³/h]	MINIMUM FLOW RATE [m³/h]	ΔT NOMINAL AIR [°C]	COUPLERS [mm]	VOLTAGE [V]	FREQUENC Y [Hz]	POWER [kW]	WEIGHT [kg]
ACC400005	315 - 3	1200	320	9,3	315	400	50	3	8,5
ACC400006	315 - 4	1600	430	9,3	315	400	50	4	8,5
ACC400007	355 - 6	2200	640	10,2	355	400	50	6	8,5
ACC400008	400 - 12	3200	1280	14	400		50	12	10
ACC400009	400 - 16	4000	1710	14,9	400		50	16	10

INSTALLATION

The battery is pre-arranged to be connected to circular pipes of nominal diameter as shown in the table. The seal is provided by the gasket on the battery neck.

The electrical battery can be installed in any position with the exception of the electrical panel facing down. This is to prevent condensation from causing short circuits.

Make sure that the length of the pipe, before and after the battery, is at least twice the diameter of the pipe itself.

Make sure that the battery only turns on when the heat recovery unit fan is switched on.

The minimum air flow rate inside the battery must be 1.5m/s. Coil shutdown must be ensured if the air flow falls below the minimum threshold.

Battery start up must be dependent on the operation of the recovery unit. For this reason, it is useful to use an air flow

sensor in the pipe to block the operation of the heater in the event of a malfunction of the heat recovery unit.

WIRING DIAGRAM

The electrical connections must be made by authorised and professionally qualified technicians and they must comply with current regulations.

The power cables must be fed into the electrical box using the cable glands on the side.

For the battery connection, strictly observe the wiring diagram attached.

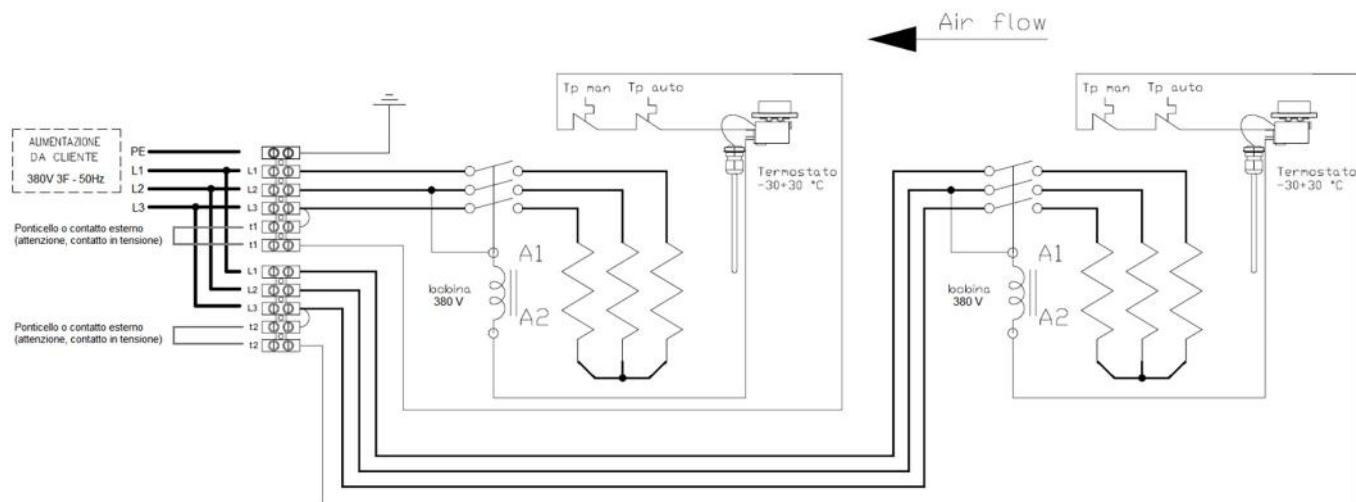

ITEMS

CODE	DESCRIPTION
ACC400005	ELECTRICAL BATTERIES WITH THERMOSTAT Ø315 3 kW FOR HEAT RECOVERY UNITS
ACC400006	ELECTRICAL BATTERIES WITH THERMOSTAT Ø315 4 kW FOR HEAT RECOVERY UNITS
ACC400007	ELECTRICAL BATTERIES WITH THERMOSTAT Ø355 6 kW FOR HEAT RECOVERY UNITS
ACC400008	ELECTRICAL BATTERIES WITH THERMOSTAT Ø400 12 kW FOR HEAT RECOVERY UNITS
ACC400009	ELECTRICAL BATTERIES WITH THERMOSTAT Ø450 16 kW FOR HEAT RECOVERY UNITS

All rights relating to this publication are the exclusive property of Tecnosystemi SpA. Tecnosystemi SpA reserves the right to make changes at any time and without notice, for technical or commercial needs.