

AirFor 3 CR

Centrifugal air curtain with front extraction with electric heating element

- cod. 12450090R2 - cod. 12450100R2 - cod. 12450110R2

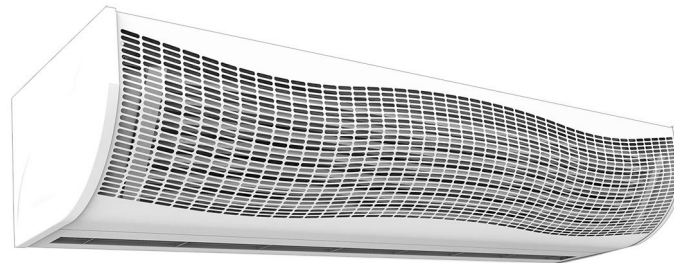

TECHNICAL SPECIFICATIONS:

- 3 models in white with speed controller supplied
- 3 speeds operated by remote control
- Air curtains are designed for indoor use
- Front air intake
- The unit must be installed horizontally
- Maximum installation height 3.5 m

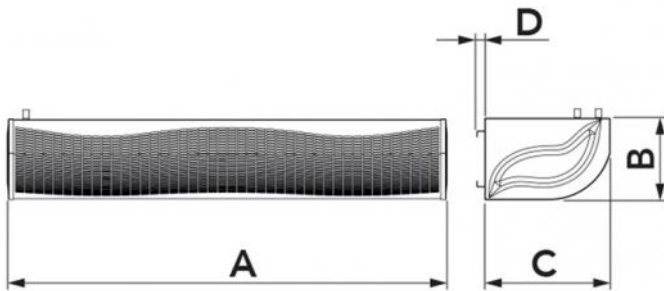

DIMENSIONS

CODE	MODEL	A [mm]	B [mm]	C [mm]	D [mm]	SUITABLE FOR LARGE DOORS [mm]
12450090R2	1000	1010	280	425	25	L.1000 H.3500
12450100R2	1500	1510	280	425	27	L.1500 H.3500
12450110R2	2000	2010	280	425	27	L.2000 H.3501

TECHNICAL DATA

CODE	SUPPLY VOLTAGE [V]	FREQUENCY [Hz]	POWER CONSUMPTION [W]	AIR SPEED AT INLET [m/s]	AIR FLOW RATE [m³/h]	SOUND POWER LEVEL [DB(A)]	ΔT AIR WITH HEATING ELEMENTS [°C]	POWER CONSUMPTION WITH PARTIAL LOAD RESISTANCE [W]	POWER ABSORBED WITH FULL LOAD RESISTANCE [W]	WEIGHT [kg]
12450090R2	400 ac	50	180	I:10 II:11.5 III:12.5	I:1288 II:1430 III:1590	I:56 II:59 III:62	19	3800	5700	33
12450100R2	400 ac	50	240	I:10 II:11.5 III:12.5	I:1717 II:1908 III:2120	I:58 II:61 III:64	17	6400	9600	48
12450110R2	400 ac	50	360	I:10 II:11.5 III:12.5	I:2584 II:2870 III:3190	I:60 II:63 III:66	17	7600	11400	67

REMOTE CONTROL

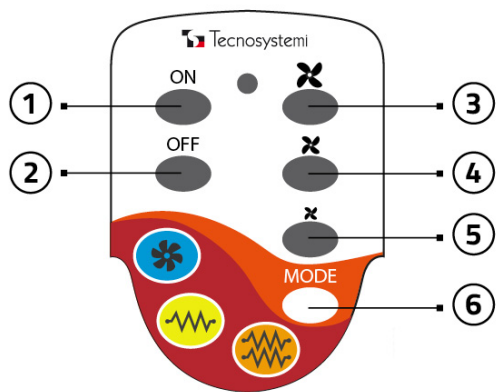

- [1] ON / Turns the appliance on
- [2] OFF / Shuts the appliance off
- [3] Maximum speed
- [4] Medium speed
- [5] Low speed
- [6] Selection of heating element

DASHBOARD LABEL

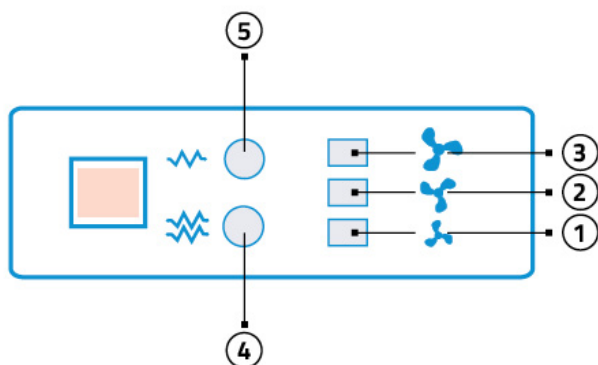

- [1] 1st speed (Min) 1 LED LIT
- [2] 2nd speed (Med) 2 LEDS LIT
- [3] 3rd speed (Max) 3 LEDS LIT
- [4] Heating element at full load (orange LED)
- [5] Heating element at partial load (yellow LED)

AUTOMATIC START KIT FOR AIR CURTAINS.

This kit, sold separately from the air curtain, allows you to switch the machine on and off by opening and closing the door.



INSTALLING AND COMMISSIONING THE AUTOMATIC START KIT (optional)

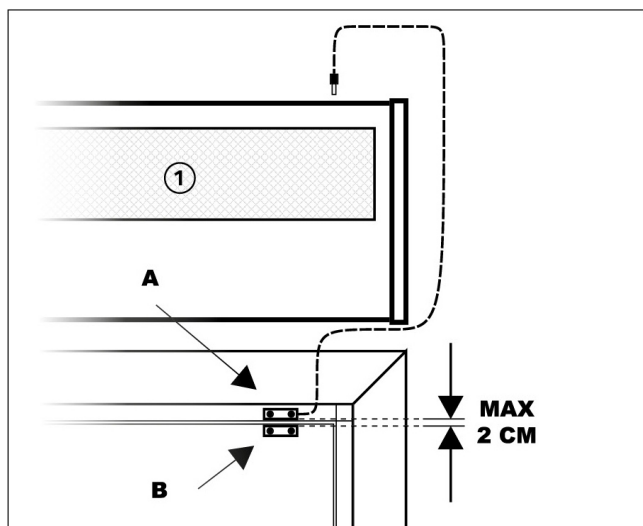

[1] Air curtain

Connect the wired sensor to the air curtain via jack.
Attach the magnetic sensor A to the door casing or to a solid point with the door frame.
Attach the second sensor to the moving part of the door leaving no more than 2 cm between the two sensors.
When the “automatic start kit” is installed, the air curtain can be switched on and off with the opening / closing of the door.

THREE-PHASE POWER SUPPLY AND WIRING DIAGRAM

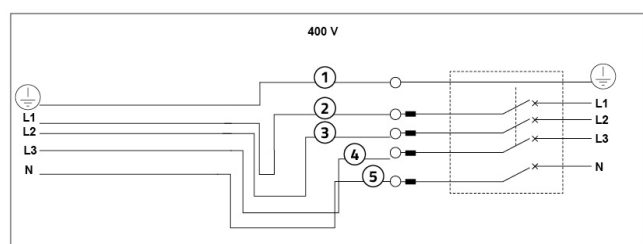

[L1 - L2 - L3] Connect the line conductor: all safety guards are fitted inside
[N] Connect the neutral connector
Connect the conductor [1] having a length greater than 1 cm compared to [L1] and [N]
[1] YELLOW/GREEN
[2] BROWN
[3] BLACK
[4] WHITE
[5] BLUE
IMPORTANT!

During the electrical connection, the installer must comply with the polarities indicated by the plate in front of the power supply terminal board.

WALL-MOUNTED DRILLING SPACING MODEL 1000

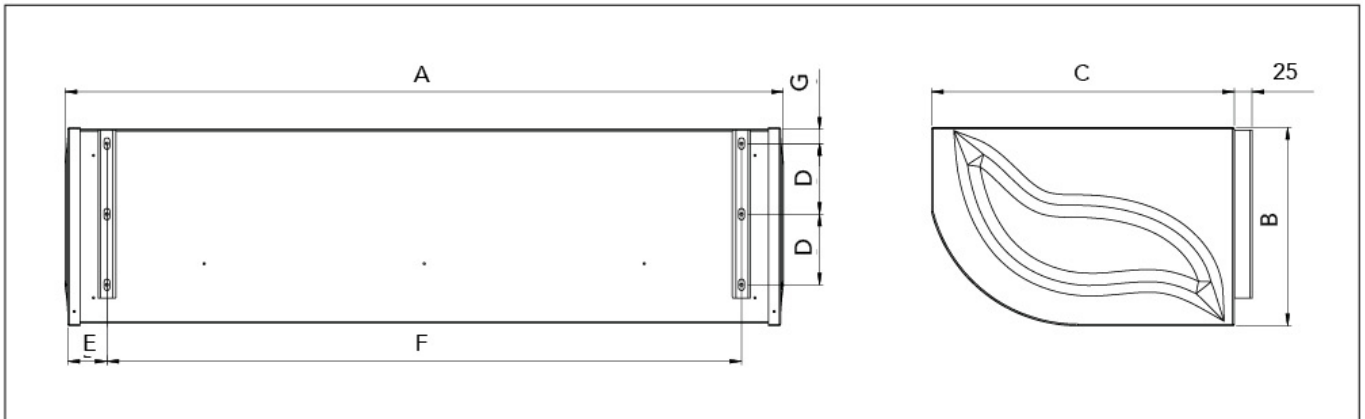

DIMENSIONAL TABLE

CODE	A [mm]	B [mm]	C [mm]	D [mm]	E [mm]	F [mm]	G [mm]
12450090R2	1010	280	425	99	55	895	20

WALL-MOUNTED DRILLING SPACING MODEL 1500

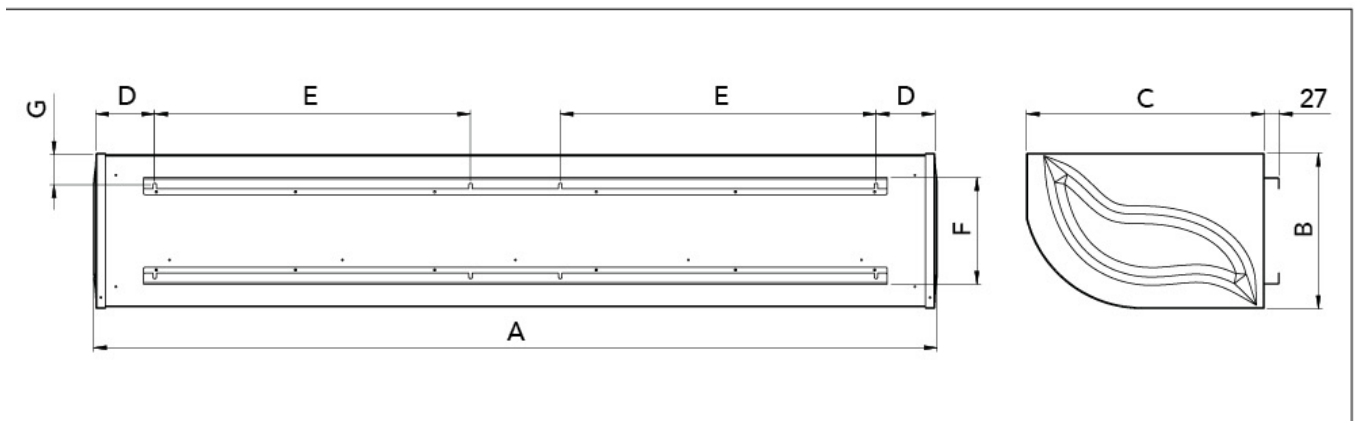

DIMENSIONAL TABLE

CODE	A [mm]	B [mm]	C [mm]	D [mm]	E [mm]	F [mm]	G [mm]
12450090R2	1510	280	425	105	565	190	55

WALL-MOUNTED DRILLING SPACING MODEL 2000

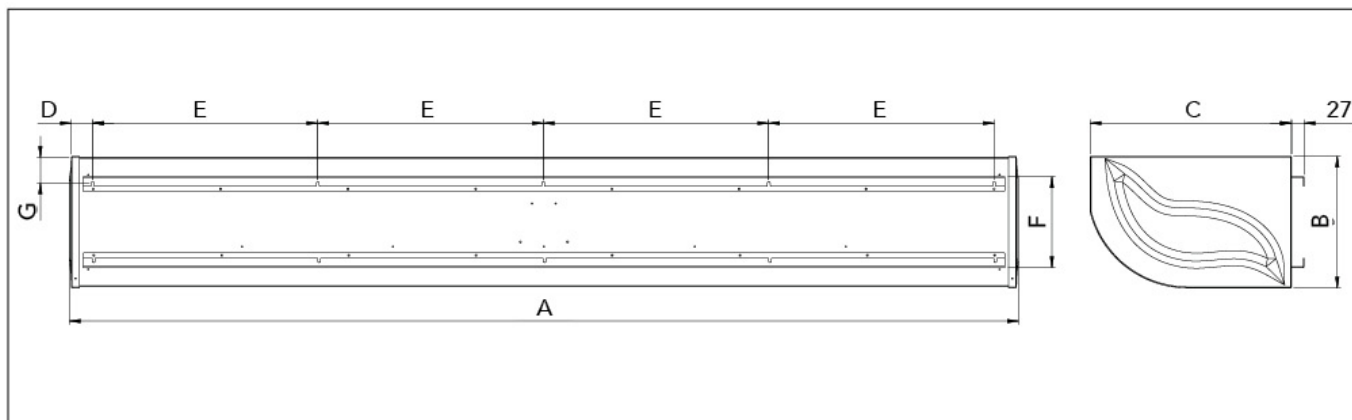

DIMENSIONAL TABLE

CODE	A [mm]	B [mm]	C [mm]	D [mm]	E [mm]	F [mm]	G [mm]
12450090R2	2010	280	425	45	478	190	55

ITEMS

CODE	DESCRIPTION
12450090R2	"AIRFOR3 CR" CENTRIFUGAL AIR CURTAINS WITH 3 ELECTRIC HEATING ELEMENTS 100
12450100R2	"AIRFOR3 CR" CENTRIFUGAL AIR CURTAINS WITH 6 ELECTRIC HEATING ELEMENTS 1500
12450110R2	"AIRFOR3 CR" CENTRIFUGAL AIR CURTAINS WITH 6 ELECTRIC HEATING ELEMENTS 2000

All rights relating to this publication are the exclusive property of Tecnosystemi SpA.
 Tecnosystemi SpA reserves the right to make changes at any time and without notice, for technical or commercial needs.