

AIR PUR EVO PLUS

Ductable sensible heat recovery unit for ceiling installation with automatic mechanical bypass

- cod. 12500050 - cod. 12500080 - cod. 12500140
- cod. 12500200 - cod. 12500230 - cod. 12500290
- cod. 12500350

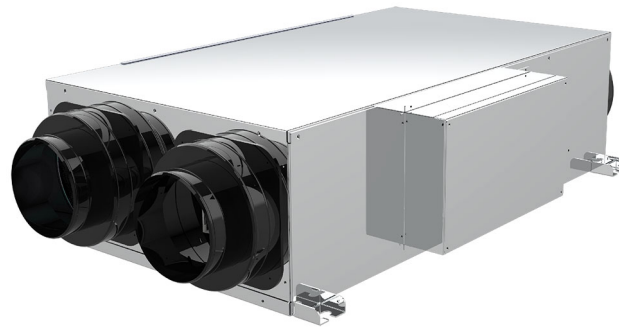

DESCRIPTION

Tecnosystemi heat recovery units in versions 200-300-500-800-1000-1300-1600-2100-2500-3000 and 4000 are used for the balanced ventilation of commercial activities (shops, restaurants, etc.), residential rooms and in any case are adaptable to any environment where it is necessary to have an air exchange, while at the same time avoiding the dispersion of the indoor temperature.

The principle of the recovery unit is to continuously introduce fresh and clean air taken from the outside and at the same time expel to the outside the stale air contained in the rooms together with smoke, odours, etc..

What makes this type of operation possible is the exchanger pack inside the heat recovery unit.

Thanks to the structure of the exchange pack, the air expelled outside transfers its heat to the incoming clean air without the two air flows ever coming into contact with each other in any way.

Two filters inserted in the recovery unit in front of the intake openings ensure the entry of air purified of particles and dust.

The advantages of wall-mounted installation in case of overhauling of heating or air conditioning systems are evident: no intervention on the wall for the insertion of the pipes, therefore no debris and dust, no cost of plastering and painting of the walls, short installation times, therefore considerable cost savings and no inconvenience.

TECHNICAL SPECIFICATIONS:

- Crossflow heat exchanger in plastic material
- Removable grade G4 filters

- Coupling for condensate drain
- Internal insulation
- Heating batter (on request)
- Anchor brackets
- Includes wall-mounted control panel with dirty filter alert
- Equipped with automatic mechanical bypass activation

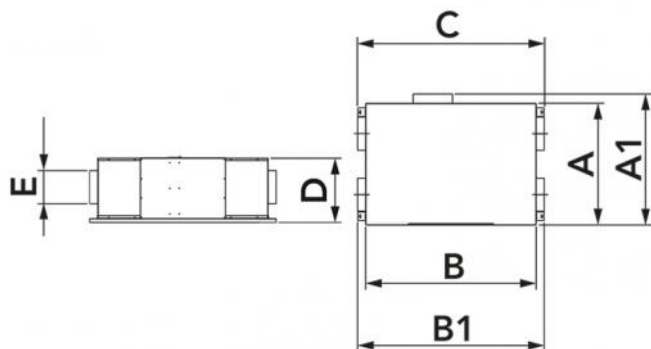

DIMENSIONS

CODE	MODEL	A [mm]	A1 [mm]	B [mm]	B1 [mm]	C [mm]	D [mm]	E [mm]
12500050	AIR PUR 300E EVO PLUS	650	720	950	1147	1006	280	150
12500080	AIR PUR 500E EVO PLUS	750	820	1100	1297	1156	320	200
12500140	AIR PUR 800E EVO PLUS	750	820	1100	1223	1156	377	250
12500200	AIR PUR 1300E EVO PLUS	930	1000	1300	1423	1421	490	250
12500230	AIR PUR 1700E EVO PLUS	1100	1170	1500	1623	1621	490	300
12500290	AIR PUR 2500E EVO PLUS	1300	1370	1600	1723	1721	540	350
12500350	AIR PUR 4000E EVO PLUS	1400	1470	1670	1793	1791	688	450

RENEWAL

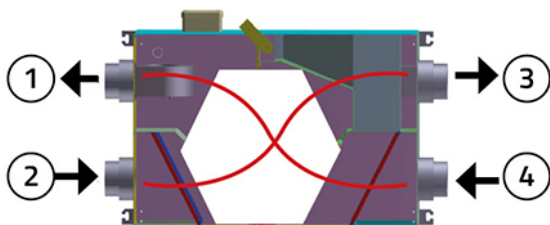

- [1] TREATED AIR DELIVERY
- [2] ROOMS AIR INTAKE
- [3] FOUL AIR EXPULSION
- [4] OUTDOOR AIR INTAKE

By operating the heat recovery unit, when the air quality falls below the comfort level, air coming from outside is introduced into the rooms.

To reduce the energy requirement necessary to bring the outdoor air temperature to the desired conditions, a cross-flow recovery unit is used which, using the energy of the foul air, is able to pre-treat and reduce the thermal difference of the renewal air.

The fan with low consumption and high prevalence expels the foul and energetically exhausted air through the outlet of the heat recovery unit.

FREE-COOLING

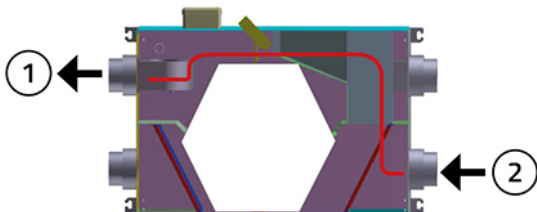

- [1] TREATED AIR DELIVERY
- [2] OUTDOOR AIR INTAKE

When the outside air conditions are good, i.e., when the summer temperature is cooler than the room temperature, the internal by-pass damper automatically operates and excludes the cross-flow heat recovery unit so as not to reduce the comfort characteristics of the outside air compared to the indoor air and reduce energy consumption for ventilation.

In winter, the logic is reversed and the conditions for which Free-Cooling is activated are an outside air temperature higher than the intake temperature of the stale air present in the various rooms.

In any case, if the external temperature deviates too much from the value desired in the environment, even if beneficial, the Free-Cooling mode is not activated, therefore the mitigating passage through the exchanger takes place always giving priority to comfort.

TECHNICAL DATA

MODEL	AIR FLOW RATE [m³/h]	HEAD [Pa]	EXCHANGE EFFICIENCY [%]	SOUND POWER LEVEL [DB(A)]	VOLTAGE [V]	FREQUENCY [Hz]	POWER CONSUMPTION [W]	WEIGHT [kg]
AIR PUR 300E EVO PLUS	300	430	75	40	230	50	200	55
AIR PUR 500E EVO PLUS	500	400	75	42	230	50	280	70
AIR PUR 800E EVO PLUS	800	400	75	58	230	50	420	84
AIR PUR 1300E EVO PLUS	1300	330	74	65	230	50	1100	135
AIR PUR 1700E EVO PLUS	1700	315	72	65	230	50	1100	203
AIR PUR 2500E EVO PLUS	2500	690	70	62	230	50	2080	211
AIR PUR 4000E EVO PLUS	4000	540	70	79	400	3 ~ 50	3000	290

PERFORMANCE GRAPHS "AIR PUR EVO PLUS 300 m³/h"

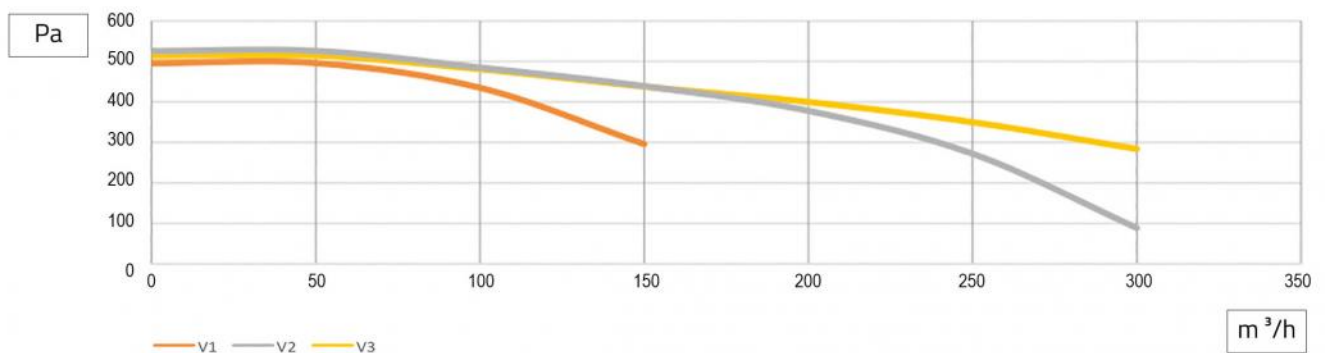

PERFORMANCE GRAPHS "AIR PUR EVO PLUS 500 m³/h"

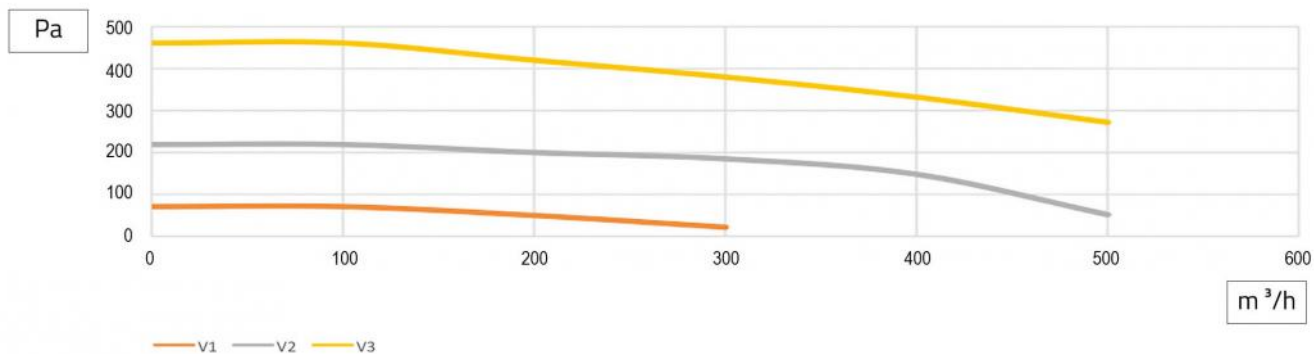

PERFORMANCE GRAPHS "AIR PUR EVO PLUS 800 m³/h"

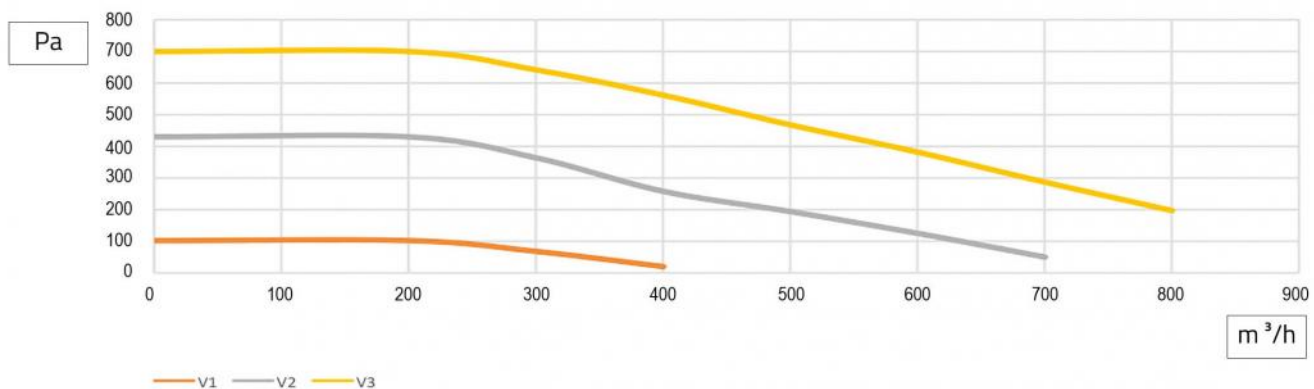

PERFORMANCE GRAPHS "AIR PUR EVO PLUS 1300 m³/h"

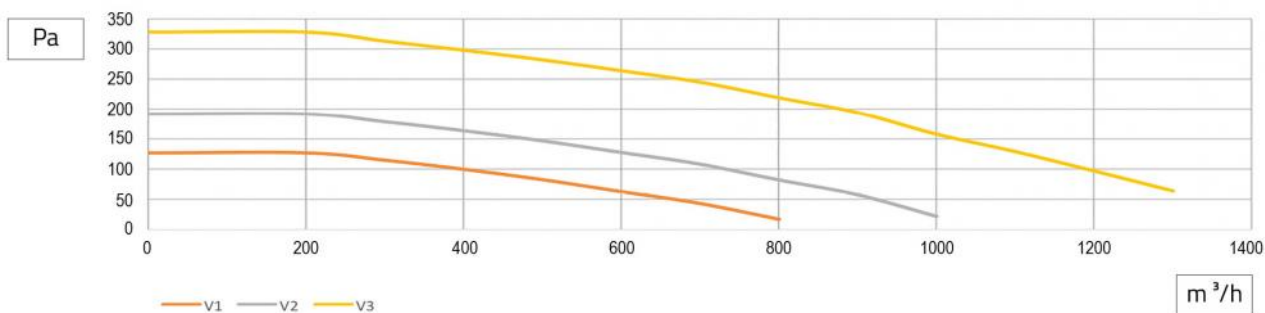

PERFORMANCE GRAPHS "AIR PUR EVO PLUS 1700 m³/h"

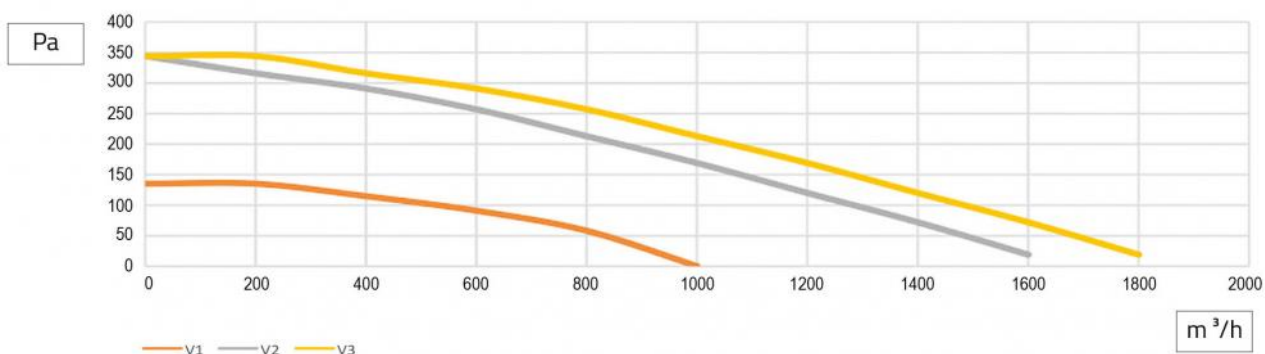

PERFORMANCE GRAPHS "AIR PUR EVO PLUS 2500 m³/h"

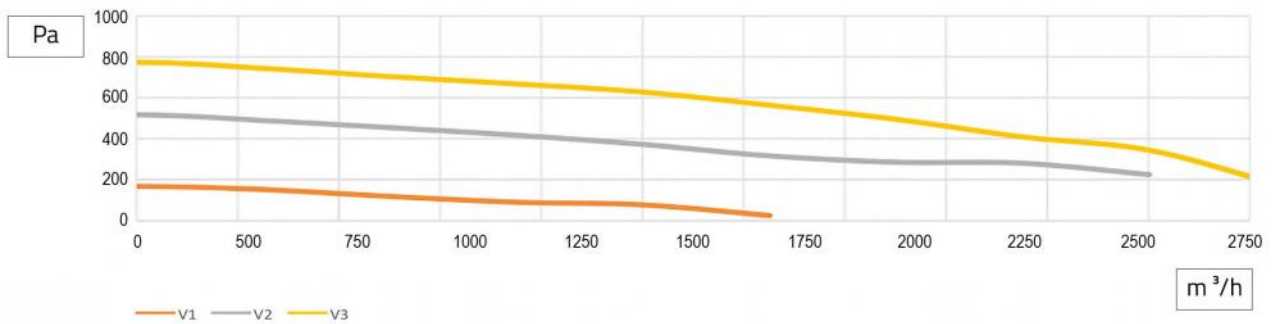

PERFORMANCE GRAPHS "AIR PUR EVO PLUS 4000 m³/h"

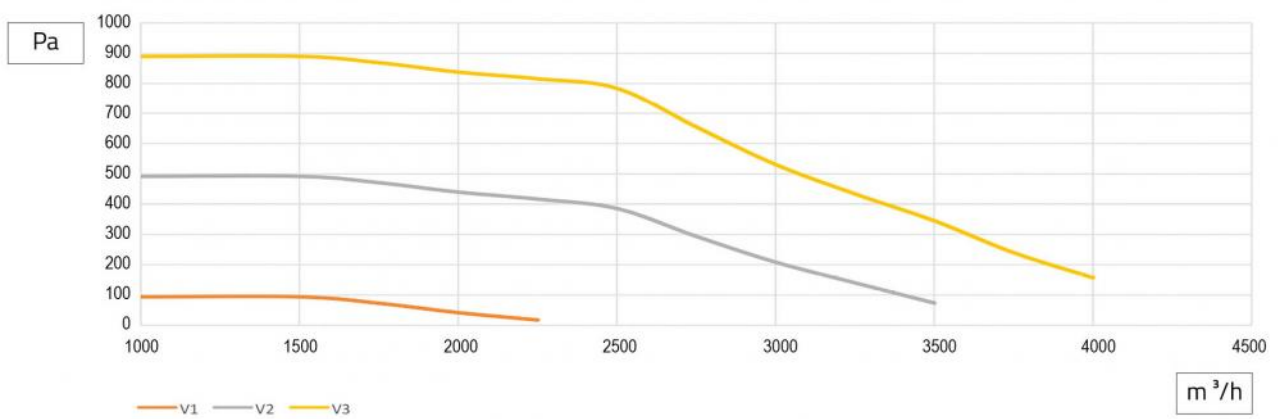

MAINTENANCE AND REMOVAL OF FILTERS

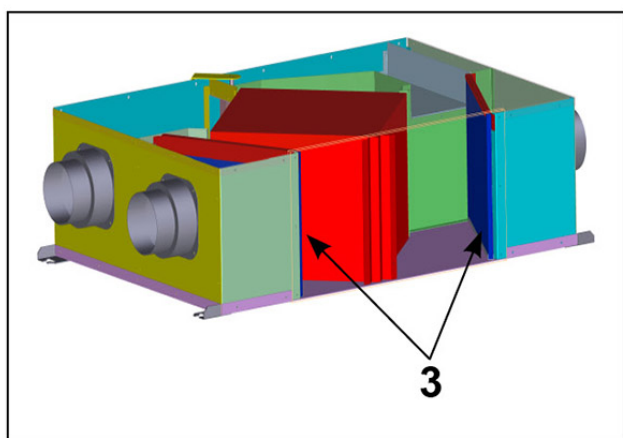
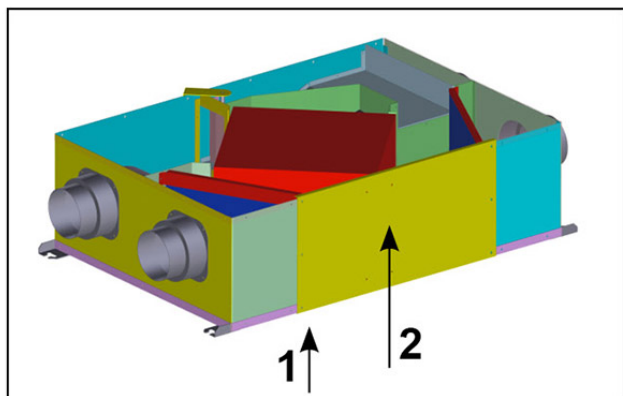

The filter structure at each inlet and outlet of the renewal air allows the filter to be removed from the side.

Operating sequence:

- tighten the fastening screws (1);
- remove the side buffer panel (2) from the main body of the heat recovery unit;
- Remove the filter (3) with the help of a screwdriver if necessary
- remove dust and miscellaneous residues using an air jet;
- reinsert the filter, reposition the buffer panel paying attention to the alignment of the holes and secure with screws.

Note: The filter acts as a mechanical barrier to the passage of unwanted particles.

ATTENTION: An access area must be provided for the removal of the filter and exchange pack.

HEAT RECOVERY UNIT INSTALLATION DIAGRAM

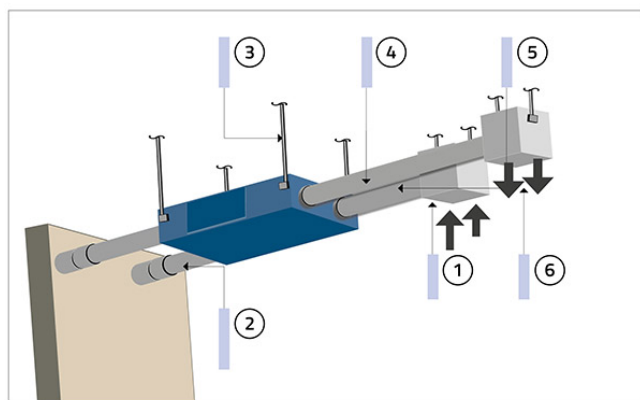

- [1] Air intake
- [2] Intake duct from the outside
- [3] Fastenings of the machine to the ceiling
- [4] Delivery air passage duct
- [5] Recovery air passage duct
- [6] Air delivery

CONTROL PANEL

During normal operation, the display shows, in addition to the day of the week and the current time, the state of the ventilators, the measurement of the room probe, and the operating mode.



- [1] Operating modes
- [2] Main field
- [3] Manual/automatic fan speed
- [4] Fan speed indication
- [5] Temperature measurement unit
- [6] Function locked
- [7] Set Point
- [8] Time slots active
- [9] Current time slots
- [10] Day of the week
- [10] Dirty filter alarm
- [12] Secondary field

ELECTRICAL CONNECTIONS

The connection required by the heat recovery unit is essentially the power supply connection. The power is nothing more than the power supply 230V-50Hz-1Ph. On the power supply line it is good to provide upstream both a disconnector and a differential circuit breaker switch.

CONNECTION OF THE HEAT RECOVERY UNIT

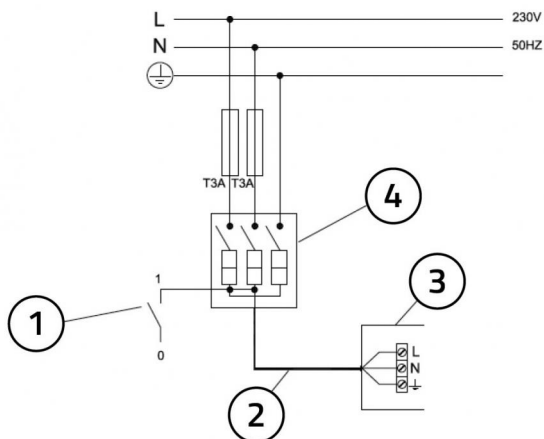

- [1] Ignition switch
- [2] Power cable 3x1.5 mm²
- [3] Electrical connection box for heat recovery unit
- [4] IMQ approved 250V main switch

CONNECTION OF THE CONTROL PANEL

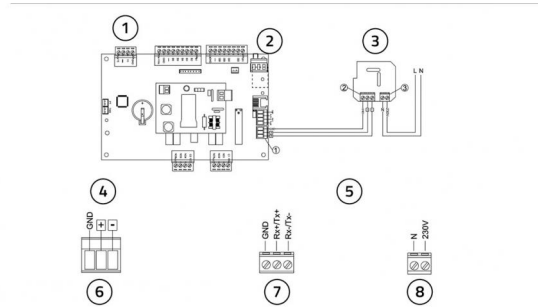

- [1] Power board on unit
- [2] Wall-, mounted control board
- [3] Power board
- [4] Wall-mounted control
- [5] Detail of the connection board to the display
- [6] Detail of clamp for the connection to the board
- [7] Detail of clamp for the connection to the network

ITEMS

CODE	DESCRIPTION
12500050	STATIC HEAT RECOVERY UNIT "AIR PUR 300E EVO PLUS"
12500080	STATIC HEAT RECOVERY UNIT "AIR PUR 500E EVO PLUS"
12500140	STATIC HEAT RECOVERY UNIT "AIR PUR 800E EVO PLUS"
12500200	STATIC HEAT RECOVERY UNIT "AIR PUR 1300E EVO PLUS"
12500230	STATIC HEAT RECOVERY UNIT "AIR PUR 1700E EVO PLUS"
12500290	STATIC HEAT RECOVERY UNIT "AIR PUR 2500E EVO PLUS"
12500350	STATIC HEAT RECOVERY UNIT "AIR PUR 4000E EVO PLUS"

All rights relating to this publication are the exclusive property of Tecnosystemi SpA.
 Tecnosystemi SpA reserves the right to make changes at any time and without notice, for technical or commercial needs.