

# TS-Humitech

Sensible heat recovery unit with ductable dehumidification unit for ceiling installation

- cod. ACC200017 - cod. ACC200019 - cod. ACC600098

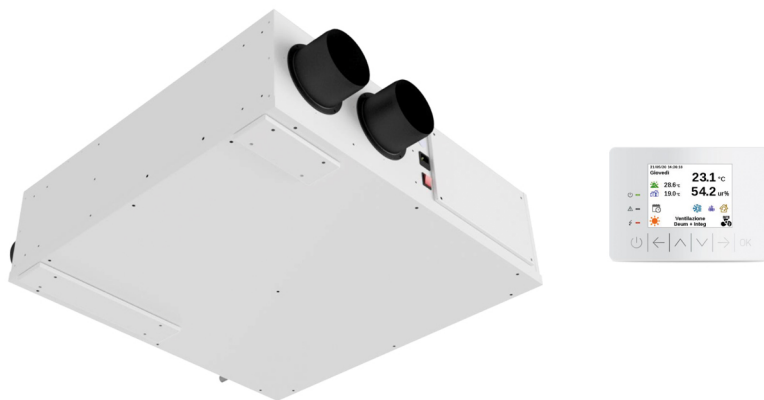

## TECHNICAL SPECIFICATIONS:

- Counter-flow heat recovery unit with >85% efficiency
- Flow rate 150 m<sup>3</sup>/h with 100 Pa of useful pressure in ventilation mode
- Dehumidification and integration with direct expansion refrigerant circuit
- Flow rate 300 m<sup>3</sup>/h with 100 Pa of useful pressure in ventilation + recirculation mode
- Flow rate 300 m<sup>3</sup>/h with 195 Pa of useful pressure in recirculation only mode
- Recovery unit by-pass damper (for free-cooling/free-heating) and integrated recirculation damper
- EC centrifugal fans, backward curved blades, low consumption
- F7 filters (ePM1 70%) with low pressure drop, both for extraction and renewal air
- Self-supporting structure in pre-painted metal sheet; thermal/acoustic insulation in expanded polyethylene thickness 10 mm
- Alphanumeric display on the machine
- Remote LCD display, with integrated temperature and humidity probes. Unit can be operated via remote contacts, remote display or via ModBus protocol on RS485
- Sensible heat exchanger

DIMENSIONS MOD.150

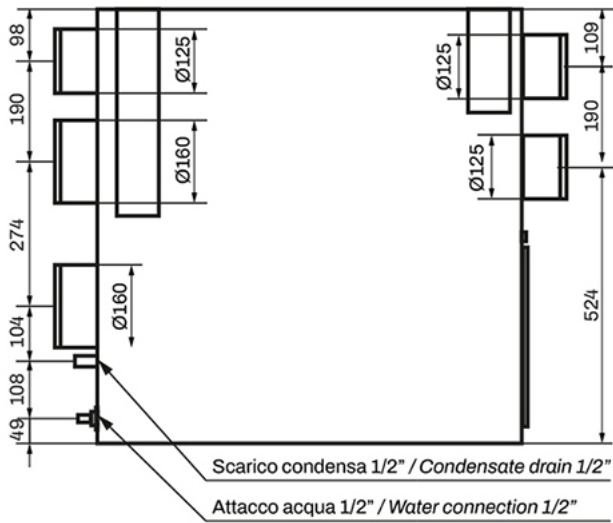
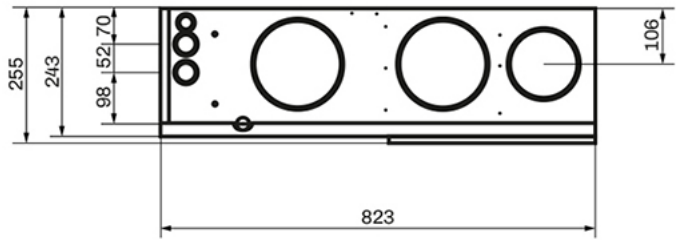
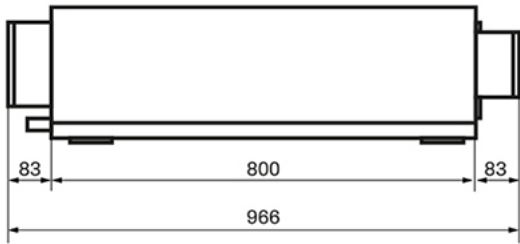

PERFORMANCE MOD. 150

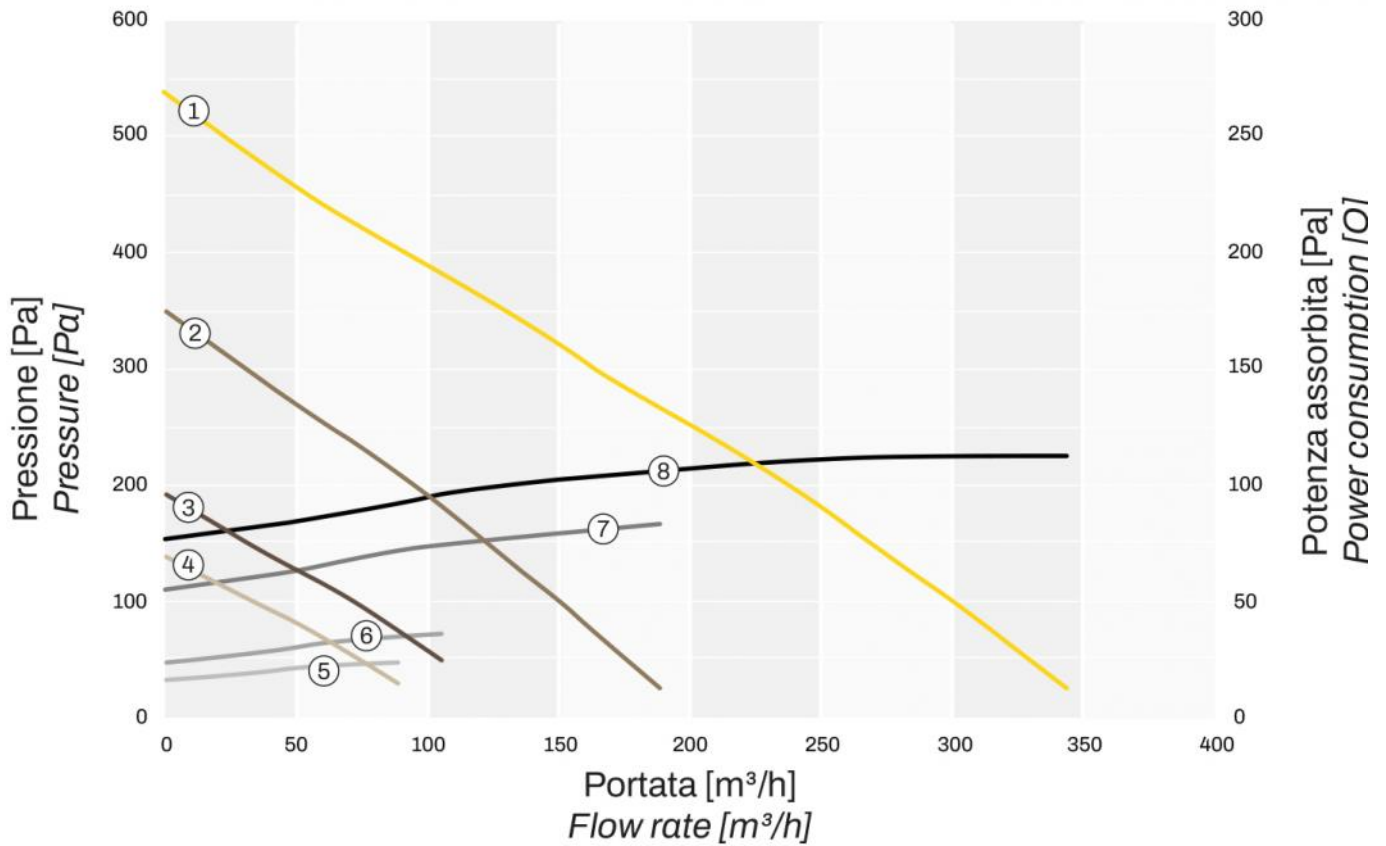

- [1] Ventilation flow rate 50%
- [2] Nominal ventilation flow rate (58%)
- [3] Maximum ventilation flow rate (78%)
- [4] Lüftungsstrom + Rezirkulation (95 %)
- [5] Power absorbed at 50% speed
- [6] Power absorbed at nominal ventilation flow rate (58%)
- [7] Power absorbed at maximum ventilation flow rate (78%)
- [8] Power absorbed at ventilation + recirculation flow rate (95%)

## THERMAL EFFICIENCY MOD. 150

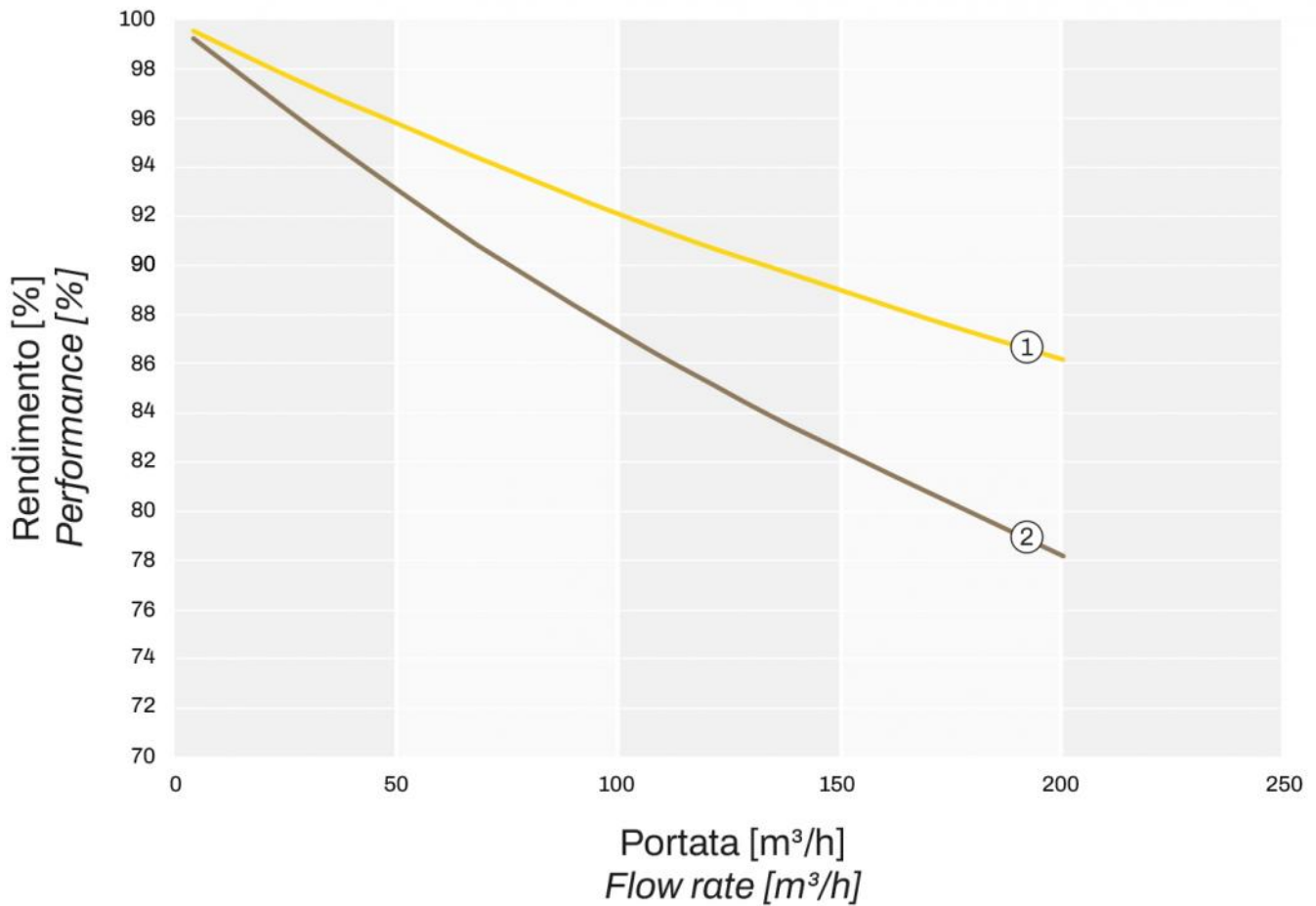

- [1] Recovery efficiency according to UNI308: external -5°C 80% ur - internal 20°C 50% ur
- [2] Recovery efficiency according to EU 1253/14: external 7°C - internal 20°C (dry)

**DIMENSIONS MOD.250**

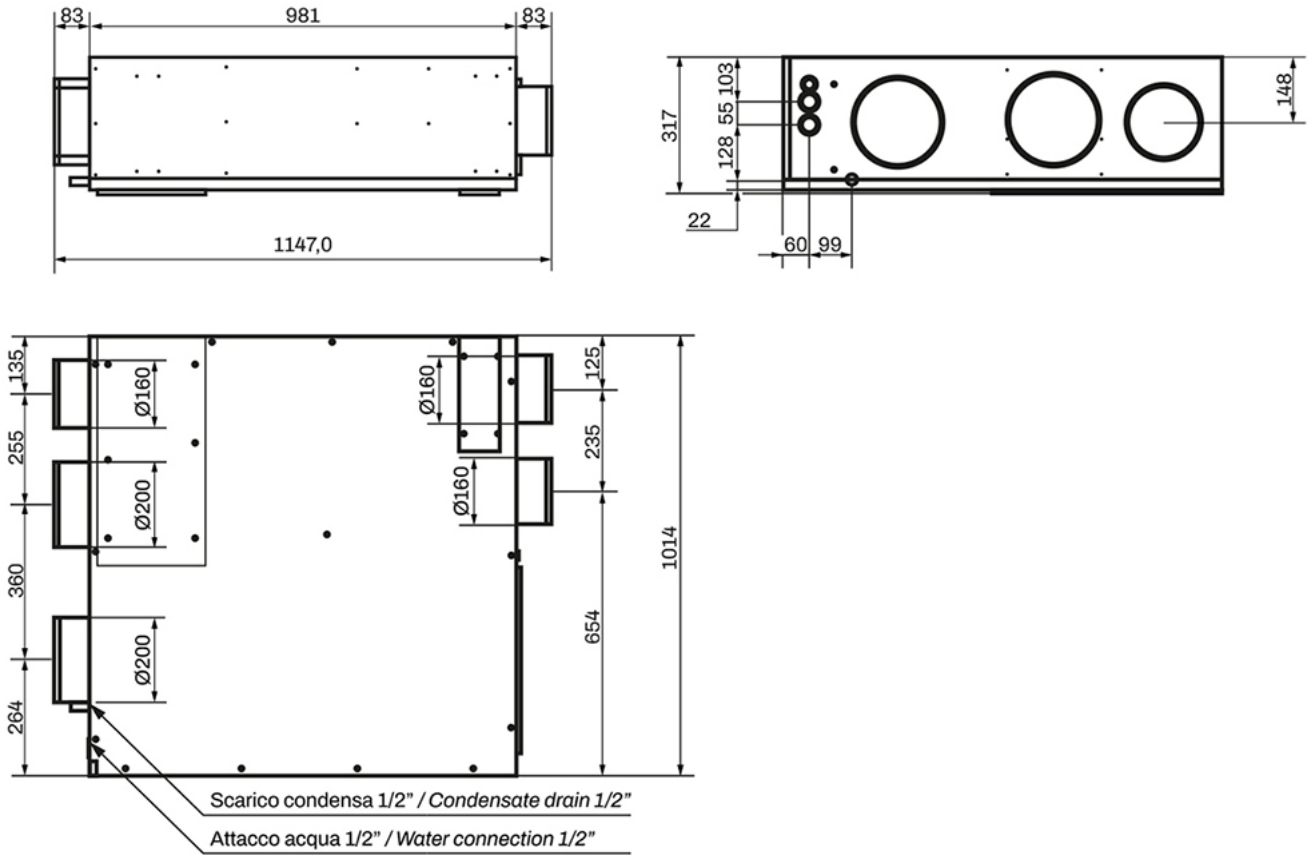

PERFORMANCE MOD. 250

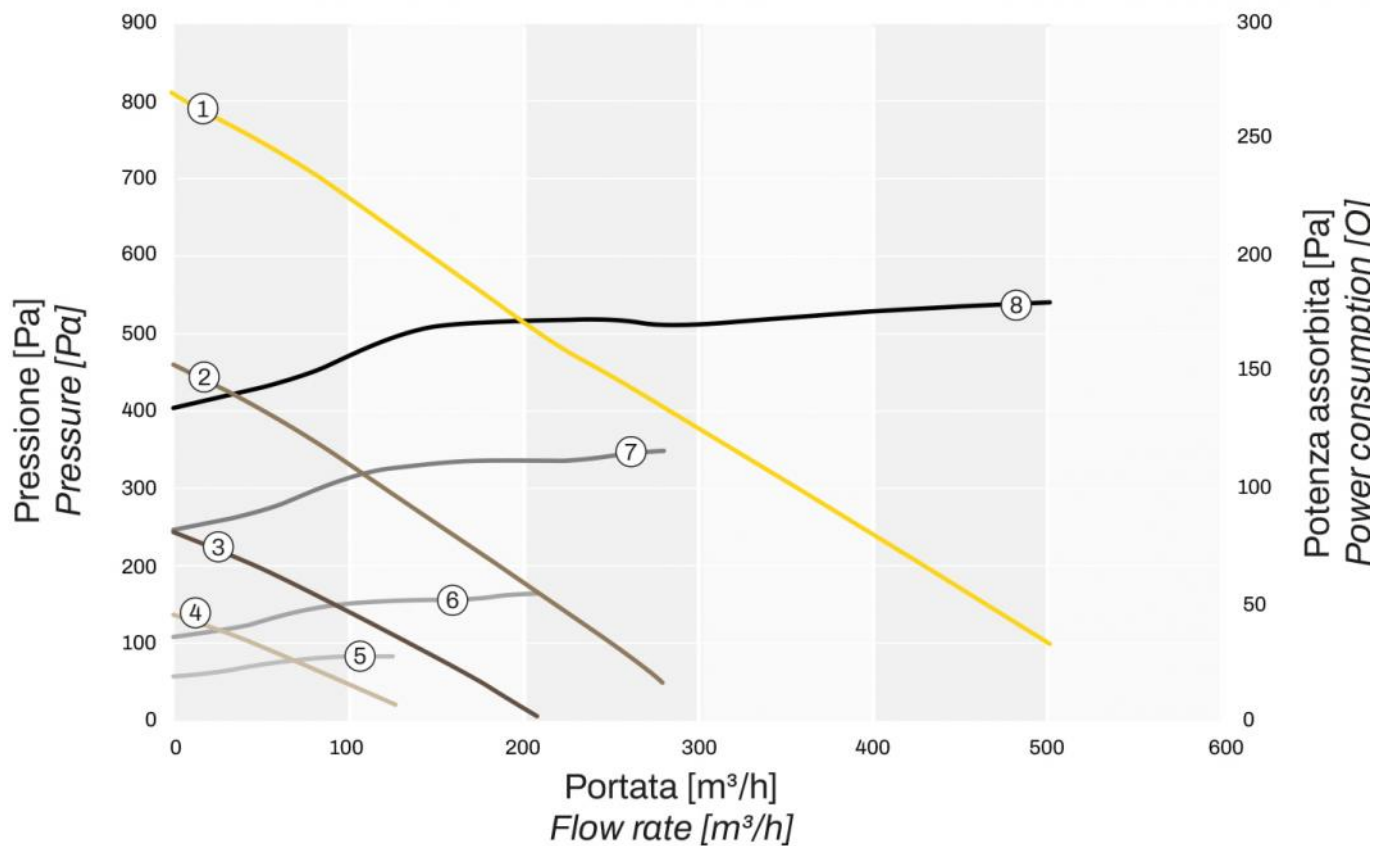

- [1] Ventilation flow rate 40%
- [2] Nominal ventilation flow rate (51%)
- [3] Maximum ventilation flow rate (70%)
- [4] Lüftungsstrom + Rezirkulation (90 %)
- [5] Power absorbed at 40% speed
- [6] Power absorbed at nominal ventilation flow rate (51%)
- [7] Power absorbed at maximum ventilation flow rate (70%)
- [8] Power absorbed at ventilation + recirculation flow rate (90%)

## THERMAL EFFICIENCY MOD. 250

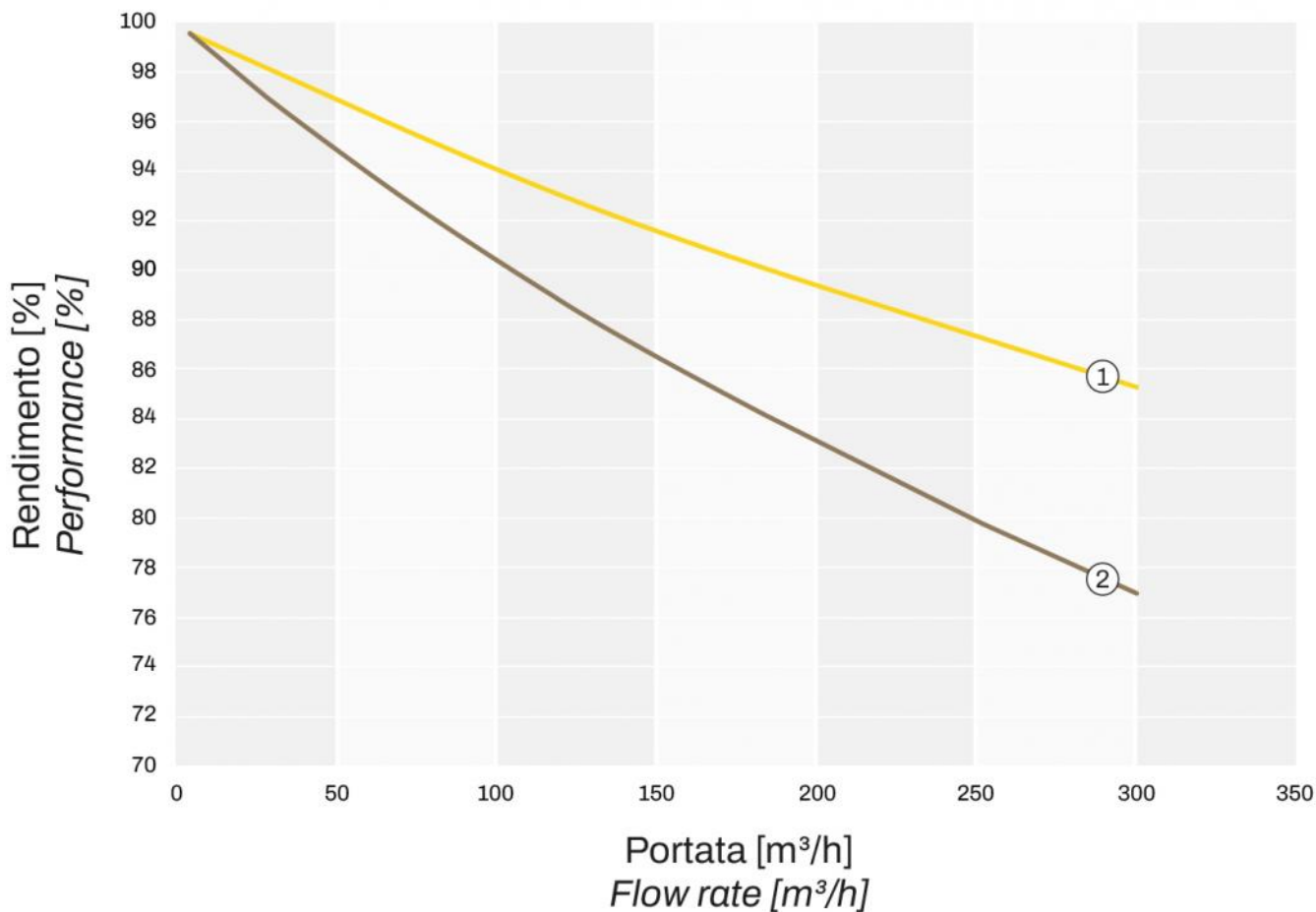

- [1] Recovery efficiency according to UNI308: external -5°C 80% ur - internal 20°C 50% ur
- [2] Recovery efficiency according to EU 1253/14: external 7°C - internal 20°C (dry)

## VENTILATION MODE

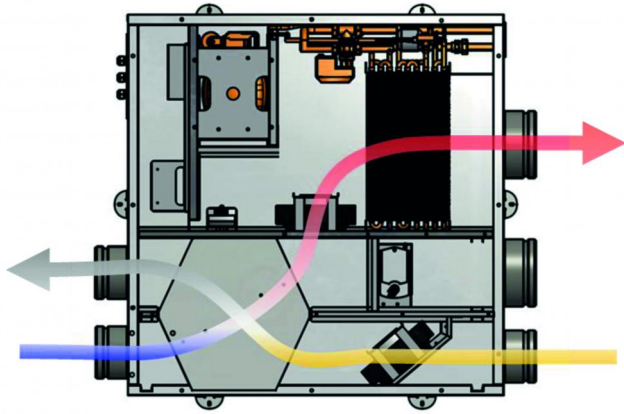

VENTILATION MODE	MODEL 150/300	MODEL 250/500
Intake air flow rate [m³/h]	150	250
Recirculated air [m³/h]	0	
Available delivery head [Pa]	100	
Expulsion air flow rate [m³/h]	150	250
Available expulsion head [Pa]	100	
Fan setting speed [%]	78	70
Electrical power consumption [kW]	0,079	0,12
Current [A]	0,64	0,94

## DEHUMIDIFICATION/INTEGRATION MODE (ventilation + recirculation)

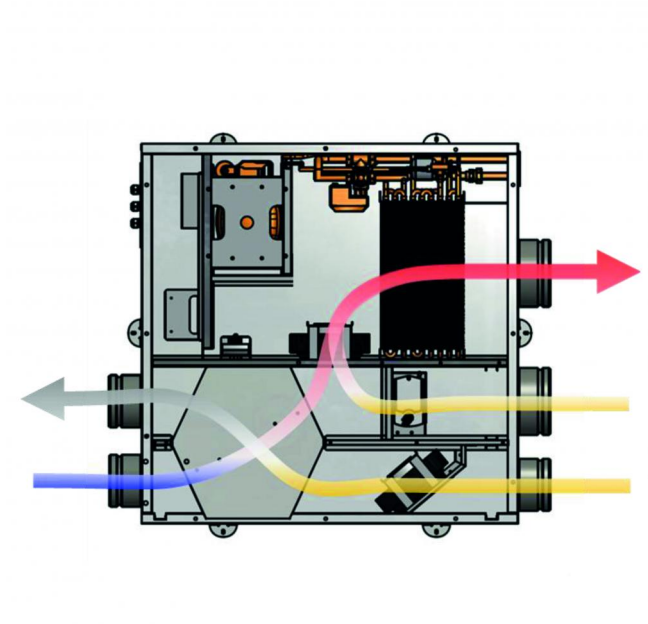

DEHUMIDIFICATION/INTEGRATION (ventilation+recirculation)	MODEL 150/300	MODEL 250/500
Intake air flow rate [m <sup>3</sup> /h]	300	500
Recirculated air [m <sup>3</sup> /h]	150	250
Available delivery head [Pa]	100	
Expulsion air flow rate [m <sup>3</sup> /h]	150	250
Available expulsion head [Pa]	100	
Refrigerant (R290) [gr]	105	150

## DEHUMIDIFICATION

DEHUMIDIFICATION	MODEL 150/300	MODEL 250/500
Ambient air	27 °C e 60% U.R.	
Outside air	35 °C e 50% U.R.	
Mixture	28 °C e 60% U.R.	
Water temperature [°C]	15	
Water flow rate [l/h]	260	500
Water side load loss [kPa]	12	28
Refrigerant power (heat recovery unit + precooler + evaporator) [kW]	0,35 + 0,85 + 1,50	0,58 + 1,30 + 1,70
Supply air temperature (Dehumidification) [°C]	24	27
Condensation capacity (Dehumidification) [l/h]	1	1.71
Power consumption (Dehumidification) (ventilation + refrigeration circuit) [kW]	0,11 + 0,29	0,18 + 0,52
Airflow (Dehumidification) (Ventilation + Refrigeration Circuit) [A]	0,92 + 1,55	1,50 + 2,80

## COOLING

COOLING	MODEL 150/300	MODEL 250/500
Ambient air	27 °C e 60% U.R.	
Outside air	35 °C e 50% U.R.	
Mixture	28 °C e 60% U.R.	
Water temperature [°C]	15	
Water flow rate [l/h]	260	500
Water side load loss [kPa]	12	28
Refrigerant power (heat recovery unit + refrigeration circuit) [kW]	0,35 + 0,95	0,58 + 1,80 (sens. P.)
Supply air temperature (Cooling) [°C]	19	17.5
Condensation capacity (Cooling) [l/h]	0,96	1,58
Power consumption (Cooling) (ventilation + refrigeration circuit) [kW]	0,11 + 0,355	0,18 + 0,57
Airflow (Cooling) (Ventilation + Refrigeration Circuit) [A]	0,92 + 1,90	1,50 + 3,05

## HEATING

HEATING	MODEL 150/300	MODEL 250/500
Ambient air	20°C e 50% U.R.	
Outside air	-5°C e 80% U.R.	
Mixture	18 °C e 50% U.R.	
Water temperature [°C]	35	
Water flow rate [l/h]	260	500
Water side load loss [kPa]	12	28
Heating power (heat recovery unit + coil) [kW]	1,10 + 0,97	1,80 + 1,80
Supply air temperature [°C]	27	28,3
Power consumption (ventilation) [kW]	0,11	0,18
Airflow (Ventilation) [A]	0,92	1,50

## DEHUMIDIFICATION/INTEGRATION MODE (recirculation only)

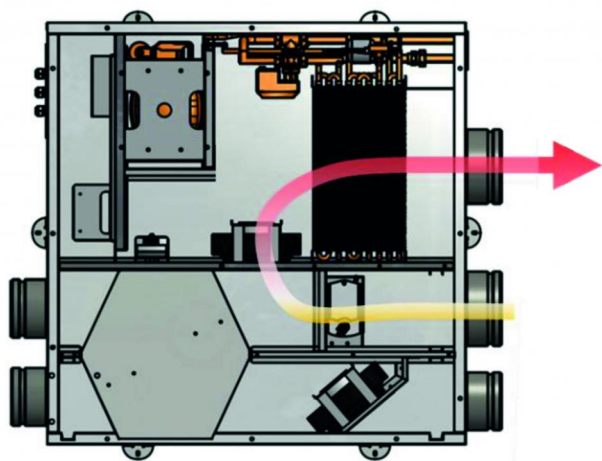

DEHUMIDIFICATION/INTEGRATION (only recirculation)	MODEL 150/300	MODEL 250/500
Intake air flow rate [m³/h]	300	500
Recirculated air [m³/h]	300	500
Available delivery head [Pa]	195	215
Expulsion air flow rate [m³/h]	0	
Available expulsion head [Pa]	0	
Refrigerant (R290) [gr]	105	150

## DEHUMIDIFICATION

DEHUMIDIFICATION	MODEL 150/300	MODEL 250/500
Ambient air	26°C e 60% U.R.	
Water temperature [°C]	15	
Water flow rate [l/h]	260	500
Water side load loss [kPa]	12	28
Refrigerant power (precooler + evaporator) [kW]	0,75 + 1,50	1,02 + 1,40
Supply air temperature (Dehumidification) [°C]	23,3	25,5
Condensation capacity (Dehumidification) [l/h]	0,92	1,46
Power consumption (Dehumidification) (recirculation + refrigeration circuit) [kW]	0,075 + 0,28	0,12 + 0,51
Airflow (Dehumidification) (Recirculation + Refrigeration Circuit) [A]	0,64 + 1,50	1,0 + 2,75

## COOLING

COOLING	MODEL 150/300	MODEL 250/500
Ambient air	26°C e 60% U.R.	
Water temperature [°C]	15	
Water flow rate [l/h]	260	500
Water side load loss [kPa]	12	28
Refrigerant power (recirculation + refrigeration circuit) [kW]	0.90	1,80 (Sens. p.)
Supply air temperature (Cooling) [°C]	17.4	16
Condensation capacity (Cooling) [l/h]	0,88	1,35
Power consumption (Cooling) (recirculation + refrigeration circuit) [kW]	0,075 + 0,345	0,12 + 0,560
Airflow (Cooling) (Recirculation + Refrigeration Circuit) [A]	0,64 + 1,85	1,0 + 3,0

## HEATING

HEATING	MODEL 150/300	MODEL 250/500
Ambient air	20 °C e 50% U.R.	
Water temperature [°C]	35	
Water flow rate [l/h]	260	500
Water side load loss [kPa]	12	28
Heating power (recirculation + coil) [kW]	1,10 + 0,97	1.40
Supply air temperature [°C]	28	
Power consumption (recirculation) [kW]	0,075	0,12
Airflow (Recirculation) [A]	0,64	1,0

## MINIMUM MAINTENANCE SPACES MODEL 150

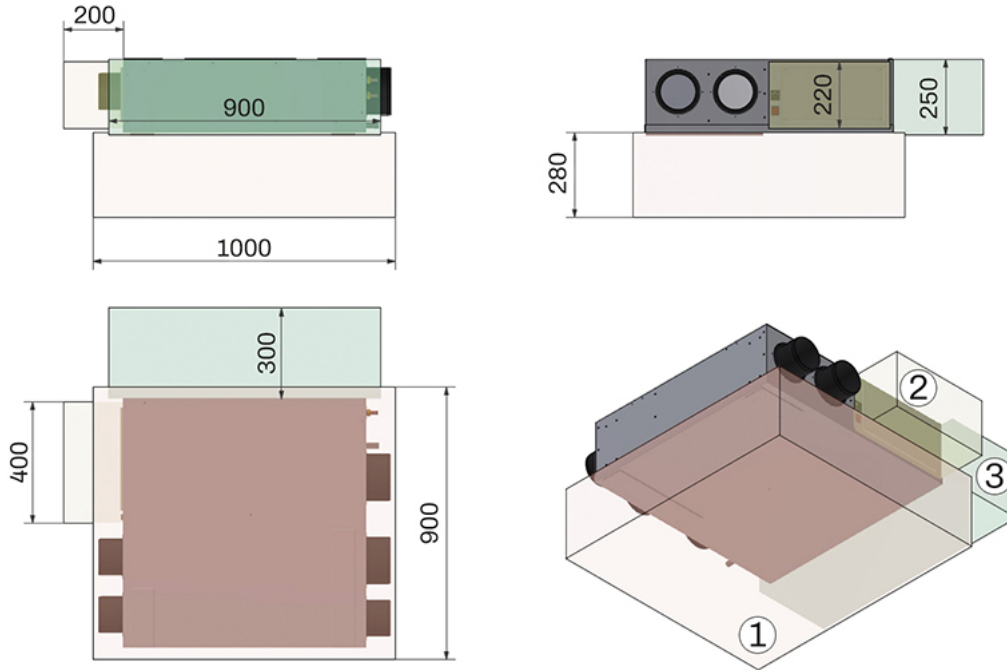

- [1] General inspection (filters from their covers)
- [2] Electrical panel inspection
- [3] Extraordinary compressor inspection

## MINIMUM MAINTENANCE SPACES MODEL 250

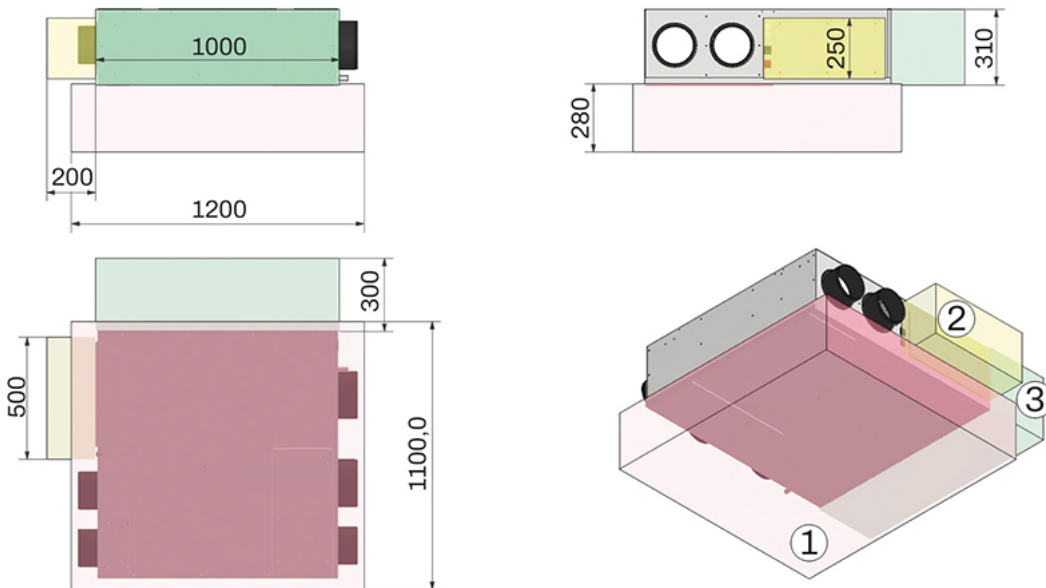

- [1] General inspection (filters from their covers)
- [2] Electrical connections
- [3] Extraordinary compressor inspection

## LCD REMOTE DISPLAY

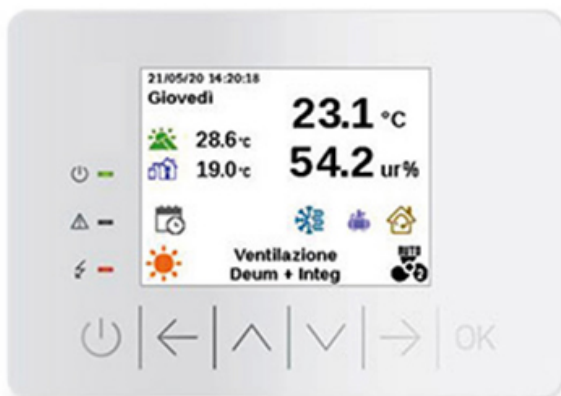

16-Colour LCD screen with 320x240 pixels, with 6-key touch keypad.

The terminal also incorporates a temperature and humidity sensor, the readings from this sensor are transmitted directly via the CAN bus, thus simplifying wiring.

- Power supply: 24 VAC/12... 30 VDC
- Max power supply length: 10m
- T sensor: built-in
- Temperature of use: 10°C to 55°C
- ur sensor: built-in
- Humidity of use: From 5 to 95%
- Warning buzzer: built-in
- Protection class IP30

## CONNECTION DIAGRAM DISPLAY

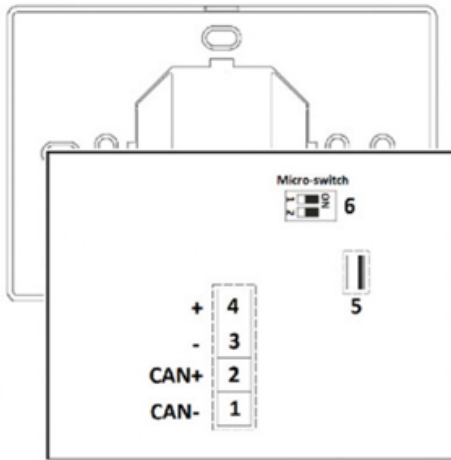

- [1] CAN port reference
- [2] Reference + CAN port
- [3] Device power supply (24 VAC/12... 30 VDC); if the device is powered by DC, connect the negative terminal.
- [4] Alimentazione dispositivo (24 VAC/12... 30 VDC); se il dispositivo è alimentato in corrente continua, collegare il terminale positivo.
- [5] USB port, for the programming of the device.
- [6] Micro switch for inserting the heating element of termination of the CAN port.

## MODEL 150/300 HORIZONTAL

SPECIFICATIONS	DATA			
Supplier brand	Tecnosystemi			
Model identifier	150/300 horizontal			
Specific energy consumption in kWh/(m <sup>2</sup> .a) for each climate zone and SEC class [Cold climate]	-70,3 kWh/m <sup>2</sup> .a	-71,8 kWh/m <sup>2</sup> .a	-74,7 kWh/m <sup>2</sup> .a	-79,8 kWh/m <sup>2</sup> .a
Specific energy consumption in kWh/(m <sup>2</sup> .a) for each climate zone and SEC class [Mild climate]	-32,8 kWh/m <sup>2</sup> .a	-34,2 kWh/m <sup>2</sup> .a	-36,7 kWh/m <sup>2</sup> .a	-41,0 kWh/m <sup>2</sup> .a
Specific energy consumption in kWh/(m <sup>2</sup> .a) for each climate zone and SEC class [Warm climate]	-8,7 kWh/m <sup>2</sup> .a	-10,0 kWh/m <sup>2</sup> .a	-12,2 kWh/m <sup>2</sup> .a	-16,1 kWh/m <sup>2</sup> .a
Energy rating	B		A	
Product type	Bidirectional UVR			
Type of drive	Variable speed			
Heat recovery system	Counter-current heat recovery unit			
Thermal efficiency of the heat recovery *	86,8 %			
Maximum flow rate [m <sup>3</sup> /h]*	150 m <sup>3</sup> /h			
Electrical power input at maximum flow rate [W]*	82 W			
Sound power level (Lwa in dB(A))	49 dB(A)			
Nominal capacity (m <sup>3</sup> /s)*	0,029 m <sup>3</sup> /s			
Pressure difference (Pa)*	50 Pa			
Specific power consumption	0,37 W/(m <sup>3</sup> /h)			
Type of control	Manual control	Timer control	Centralised environmental control	Local environmental control
Control coefficient	1,00	0,95	0,85	0,65
Leakage rate (%) [internal]	3,7%			
Leakage rate (%) [external]	5,9%			
Leakage rate (%) [recirculation]	not applicable			
Mixture rate (%)	not applicable			
Location and description of the visual warning signal relating to filters	Alarm displayed on the control unit on board the unit and on the remote display, if applicable, in addition to signalling via ModBus and with a configurable alarm contact.			
Installation for new air delivery	not applicable			
Internet address with pre-assembly and disassembly instructions	www.tecnosystemi.com			
Sensitivity of air flow to pressure changes at + 20 Pa and - 20 Pa (%)	not applicable			
Internal/external air tightness (m <sup>3</sup> /h)	not applicable			

# DATASHEET

Specific annual electricity consumption (AEC) for a 100m <sup>2</sup> dwelling (kWh electricity /a)** [Cold climate]	1042,5 kWh electr./a	997,6 kWh electr./a	914,7 kWh electr./a	776,8 kWh electr./a
Specific annual electricity consumption (AEC) for a 100m <sup>2</sup> dwelling (kWh of electricity /a)** [Mild climate]	505,5 kWh electr./a	460,6 kWh electr./a	377,7 kWh electr./a	239,6 kWh electr./a
Specific annual electricity consumption (AEC) for a 100m <sup>2</sup> dwelling (kWh electricity /a)** [Warm climate]	460,5 kWh electr./a	415,6 kWh electr./a	332,7 kWh electr./a	194,6 kWh electr./a
Specific annual heating savings for a 100m <sup>2</sup> dwelling (kWh of primary energy /a)** [Cold climate]	8764,0 kWh en.prim./a	8805,1 kWh en.prim./a	8887,4 kWh en.prim./a	9051,9 kWh en.prim./a
Specific annual heating savings for a 100m <sup>2</sup> dwelling (kWh of primary energy /a)** [Mild climate]	4480,0 kWh en.prim./a	4501,0 kWh en.prim./a	4543,0 kWh en.prim./a	4627,1 kWh en.prim./a
Specific annual heating savings for a 100m <sup>2</sup> dwelling (kWh of primary energy /a)** [Warm climate]	2025,8 kWh en.prim./a	2035,3 kWh en.prim./a	2054,3 kWh en.prim./a	2092,3 kWh en.prim./a

\* as per regulation n° 1253/2014

\*\* calcolati come da regolamento n°1254/2014

\*<sup>3</sup> sonda di umidità, di CO<sub>2</sub>/qualità aria, di presenza...

The above table reports the performance data determined in accordance with Regulations (EU) 1254/2014 and 1253/2014.

La macchina non rientra nello scopo di tali Regolamenti, motivo per cui tali dati sono da ritenersi indicativi e forniti a mero scopo informativo e relativi alla sola modalità ventilazione (no deumidificazione, no ricircolo) e non sono in alcun modo da intendersi come elementi di conformità ai succitati regolamenti.

## MODEL 250/500 HORIZONTAL

SPECIFICATIONS	DATA			
Supplier brand	Tecnosystemi			
Model identifier	250/500 horizontal			
Specific energy consumption in kWh/(m <sup>2</sup> .a) for each climate zone and SEC class [Cold climate]	-70,6 kWh/m <sup>2</sup> .a	-72,0 kWh/m <sup>2</sup> .a	-74,8 kWh/m <sup>2</sup> .a	-79,6 kWh/m <sup>2</sup> .a
Specific energy consumption in kWh/(m <sup>2</sup> .a) for each climate zone and SEC class [Mild climate]	-33,7 kWh/m <sup>2</sup> .a	-34,9 kWh/m <sup>2</sup> .a	-37,2 kWh/m <sup>2</sup> .a	-41,2 kWh/m <sup>2</sup> .a
Specific energy consumption in kWh/(m <sup>2</sup> .a) for each climate zone and SEC class [Warm climate]	-10,0 kWh/m <sup>2</sup> .a	-11,1 kWh/m <sup>2</sup> .a	-13,1 kWh/m <sup>2</sup> .a	-16,5 kWh/m <sup>2</sup> .a
Energy rating	B		A	
Product type	Bidirectional UVR			
Type of drive	Variable speed			
Heat recovery system	Counter-current heat recovery unit			
Thermal efficiency of the heat recovery *	84,7%			
Maximum flow rate [m <sup>3</sup> /h]*	250 m <sup>3</sup> /h			
Electrical power input at maximum flow rate [W]*	82 W			
Sound power level (Lwa in dB(A))	117 dB(A)			
Nominal capacity (m <sup>3</sup> /s)*	0,049 m <sup>3</sup> /s			
Pressure difference (Pa)*	50 Pa			
Specific power consumption	0,32 W/(m <sup>3</sup> /h)			
Type of control	Manual control	Timer control	Centralised environmental control	Local environmental control
Control coefficient	1,00	0,95	0,85	0,65
Leakage rate (%) [internal]	4,0%			
Leakage rate (%) [external]	6,1%			
Leakage rate (%) [recirculation]	not applicable			
Mixture rate (%)	not applicable			
"Location and description of the visual warning signal relating to filters"	Alarm displayed on the control unit on board the unit and on the remote display, if applicable, in addition to signalling via ModBus and with a configurable alarm contact.			
Installation for new air delivery	not applicable			
"Internet address with pre-assembly and disassembly instructions"	www.tecnosystemi.com			
Sensitivity of air flow to pressure changes at + 20 Pa and - 20 Pa (%)	not applicable			
Internal/external air tightness (m <sup>3</sup> /h)	not applicable			

# DATASHEET

Specific annual electricity consumption (AEC) for a 100m <sup>2</sup> dwelling (kWh electricity /a)** [Cold climate]	980,0 kWh elettr./a	941,2 kWh elettr./a	869,6 kWh elettr./a	750,2 kWh elettr./a
Specific annual electricity consumption (AEC) for a 100m <sup>2</sup> dwelling (kWh of electricity /a)** [Mild climate]	443,0 kWh elettr./a	404,2 kWh elettr./a	332,6 kWh elettr./a	213,2 kWh elettr./a
Specific annual electricity consumption (AEC) for a 100m <sup>2</sup> dwelling (kWh electricity /a)** [Warm climate]	398,0 kWh elettr./a	359,2 kWh elettr./a	287,6 kWh elettr./a	168,2 kWh elettr./a
Specific annual heating savings for a 100m <sup>2</sup> dwelling (kWh of primary energy /a)** [Cold climate]	8633,2 kWh en.prim./a	8680,8 kWh en.prim./a	8776,2 kWh en.prim./a	8966,8 kWh en.prim./a
Specific annual heating savings for a 100m <sup>2</sup> dwelling (kWh of primary energy /a)** [Mild climate]	4413,1 kWh en.prim./a	4437,5 kWh en.prim./a	4486,2 kWh en.prim./a	4583,7 kWh en.prim./a
Specific annual heating savings for a 100m <sup>2</sup> dwelling (kWh of primary energy /a)** [Warm climate]	1995,5 kWh en.prim./a	2006,6 kWh en.prim./a	2028,6 kWh en.prim./a	2072,7 kWh en.prim./a

\* as per regulation n° 1253/2014

\*\* calcolati come da regolamento n°1254/2014

\*\*3 sonda di umidità, di CO<sub>2</sub>/qualità aria, di presenza...

The above table reports the performance data determined in accordance with Regulations (EU) 1254/2014 and 1253/2014.

La macchina non rientra nello scopo di tali Regolamenti, motivo per cui tali dati sono da ritenersi indicativi e forniti a mero scopo informativo e relativi alla sola modalità ventilazione (no deumidificazione, no ricircolo) e non sono in alcun modo da intendersi come elementi di conformità ai succitati regolamenti.

## ITEMS

CODE	DESCRIPTION
ACC200017	HEAT RECOVERY UNIT WITH DEHUMIDIFICATION, HEATING INTEGRATION AND VENTILATION WITH REFRIGERANT CIRCUIT AND WATER COIL - 150/300
ACC200019	HEAT RECOVERY UNIT WITH DEHUMIDIFICATION, HEATING INTEGRATION AND VENTILATION WITH REFRIGERANT CIRCUIT AND WATER COIL - 250/500
ACC600098	ADDITIONAL HUMIDITY AND AMBIENT TEMPERATURE PROBE

All rights relating to this publication are the exclusive property of Tecnosystemi SpA.

Tecnosystemi SpA reserves the right to make changes at any time and without notice, for technical or commercial needs.