

SILENCE AIR PLUS

Wall-mounted residential enthalpy heat recovery unit, integrable into BMS systems

- cod. ACC300009 - cod. ACC300003 - cod. ACC300004
- cod. ACC300005 - cod. ACC300006



DESCRIPTION

The heat recovery unit is made in air-tight moulded ABS to prevent the formation of condensate. Ideal for wall installation.

The heat recovery unit has Brushless EC motors, RS485 communication port with MODBUS protocol and high-efficiency internal and external air filtration system.

The air quality index monitoring ensures a constant exchange of healthy air, thanks to the cross-flow enthalpy heat exchanger.

You can control the heat recovery unit easily from any mobile device using the Smart Life APP.

Can be integrated with BMS (Building automation) SYSTEMS.

DIMENSIONS

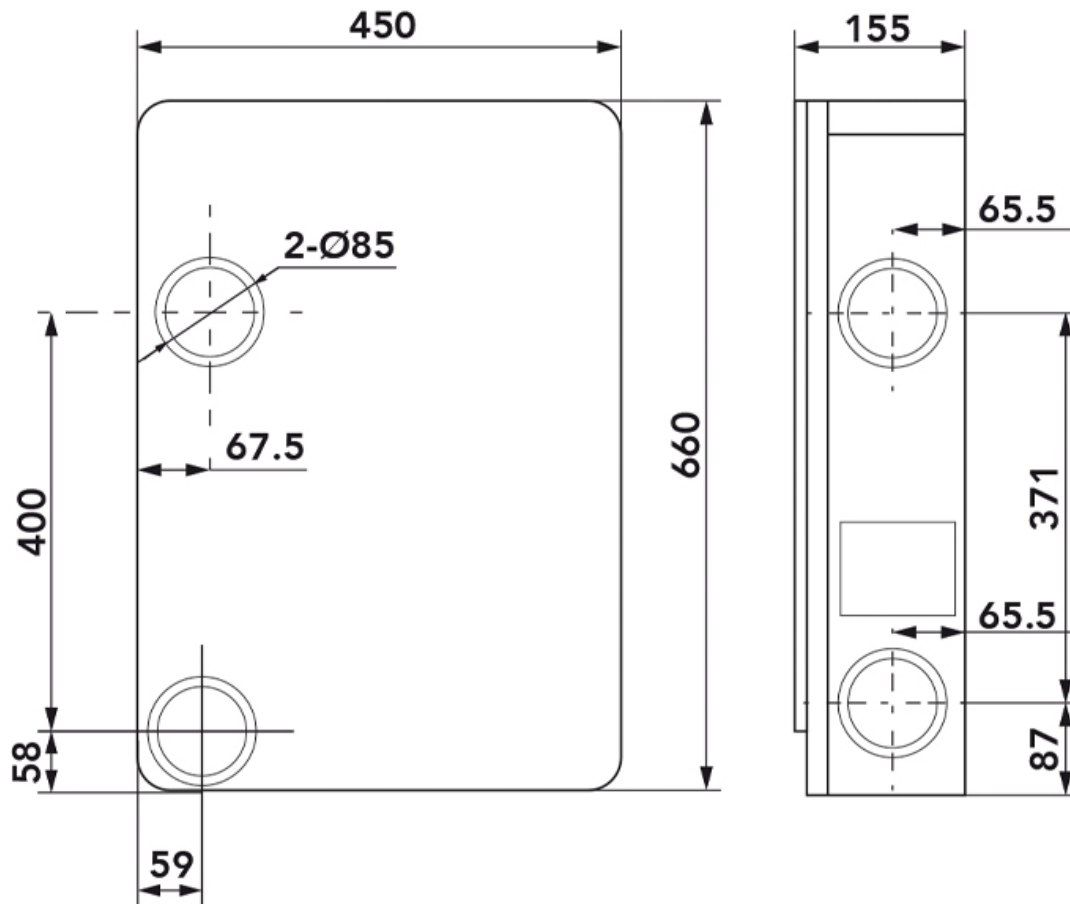

DISPLAY INTERFACE DESCRIPTION



- [1] Set clock and timer
- [2] CO2 value measured in the room
- [3] Temperature and humidity measured in the room
- [4] Operating speed
- [5] Operating mode
- [6] Functions:
 SPEED: speed setting
 MODE: operating mode
 ON/OFF: on/off switch

TECHNICAL DATA

Power supply	230V, 50Hz, single-phase
Maximum power consumption	44 W
Insulation class	Class I
IP rating	IP X2
Motors	Brushless EC
Drive	8 speeds
Maximum capacity	150 m³/h
Exchanger type	Cross-flow enthalpy
Thermal Efficiency of the Heat Exchanger (%)	82
Enthalpy Efficiency (Heating) (%)	58
Enthalpy Efficiency (Cooling) (%)	52
Sound pressure in "sleep" mode (ISO 3745)	34.6 dB(A)
Air temperature	-15°C +40 °C
Body material	ABS
Operating mode	Manual - Automatic - Timer - Sleep (silent mode) - Purification
Purifier function filter	HEPA 99%
Air quality display	Temperature, CO ₂ , relative humidity
Control	Touch-screen display / Remote control / Wi-Fi / BMS
BMS connection	RS485 protocol Modbus
Dimensions [mm]	660 x 450 x 155 mm
Weight	10 kg

ECODESIGN TECHNICAL DATA

Brand	Tecnosystemi
Model	ACC300009
Specific energy consumption (SEC, kWh/m ² /a) and Class SEC - Cold climate	-79,28 (A+)
Specific energy consumption (SEC, kWh/m ² /a) and Class SEC - Temperate climate	-40,95 (A)
Specific energy consumption (SEC, kWh/m ² /a) and Class SEC - Hot climate	-16,36 (E)
Type	UVB, UVR - Bidirectional, Residential Ventilation Unit
Driving type	variable speed
Type of heat recovery system	Recovery
Thermal efficiency of the heat recovery (%)	82
Maximum flow capacity (m ³ /h)	150
Electrical power consumption at maximum flow capacity (W)	44
Noise power level (dB(A))	48.7
Nominal capacity (m ³ /s)	0.0417
Nominal pressure difference (Pa)	0
SPI (W/m ³ /h)	0.292
Control factor	Local environmental control
Maximum internal drawing (%)	3.5
Maximum external drawing (%)	5
Mixture rate (%)	20
Air flow sensitivity to pressure variations +20Pa and -20Pa	27
Internal/external air tightness (m ³ /h)	7
Internet address with disassembly instructions	www.tecnosystemi.com
Annual electricity consumption (AEC) (kWh electrical energy) - Cold climate	7,54
Annual electricity consumption (AEC) (kWh electrical energy) - Temperate climate	2,16
Annual electricity consumption (AEC) (kWh electrical energy) - Hot climate	1,72
Annual heating savings (AHS) (kWh primary energy) - Cold climate	89,4
Annual heating savings (AHS) (kWh primary energy) - Temperate	45,7
Annual heating savings (AHS) (kWh primary energy) - Hot climate	20,66

ENERGY LABEL

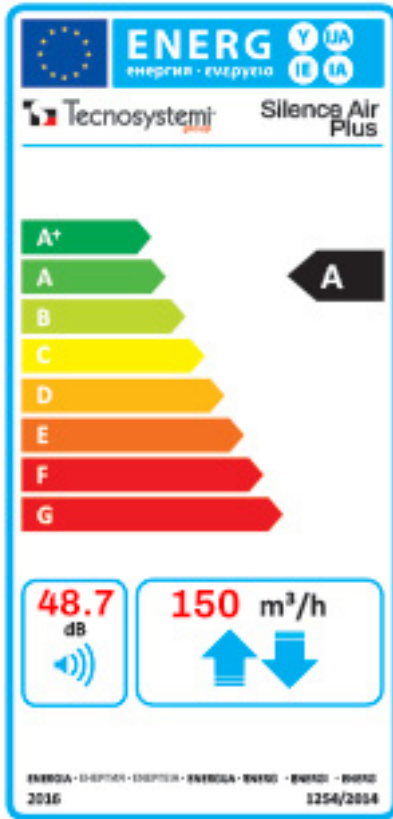

AUTOMATIC MODE AUTO

In automatic AUTO mode, the device will autonomously adjust the delivery air flow rate depending on the value of CO₂ detected inside the room, as shown in the following table.

Detected CO ₂ value	OPINION ON AIR QUALITY	OPERATING SPEED
CO ₂ ≤ 450	Excellent	1
450 < CO ₂ ≤ 1000	Good	3
1000 < CO ₂ ≤ 1500	Slightly polluted	5
1500 < CO ₂ ≤ 2000	Averagely polluted	7
2000 < CO ₂	Highly polluted	8

LIST OF THE INCLUDED ACCESSORIES



- [1] 1 installation panel
- [2] 1 power cable
- [3] 1 remote control
- [4] 2 PVC ducts
- [5] 2 caps
- [6] 2 ventilation flanges
- [7] 1 delivery air grille
- [8] 1 intake air grille
- [9] 2 rain guards

- [10] 2 rubber gaskets
- [11] 2 rear sealing gaskets
- [12] 2 side sealing gaskets
- [13] 5 sets of anchor + anchoring screw
- [14] 8 M3x12 screws
- [15] 8 M3 nuts
- [16] 4 self-threading screws

ITEMS

CODE	DESCRIPTION
ACC300009	"SILENCE AIR" RESIDENTIAL HEAT RECOVERY UNIT - WALL MOUNTED- 150 m3/h - USABLE WITH BMS SYSTEMS - SILENCE AIR PLUS
ACC300003	SPARE FILTER GRADO - GRADE F7 -FOR INLET OF OUTDOOR AIR - SUITABLE TO SILENCE AIR
ACC300004	SPARE FILTER HEPA + ACTIVATED CARBON FILTER - SUITABLE TO SILENCE AIR
ACC300005	SPARE FILTER FOR RETURN AIR- SUITABLE PER SILENCE AIR
ACC300006	HEAT EXCHANGER - SUITABLE TO SILENCE AIR

All rights relating to this publication are the exclusive property of Tecnosystemi SpA.
 Tecnosystemi SpA reserves the right to make changes at any time and without notice, for technical or commercial needs.