

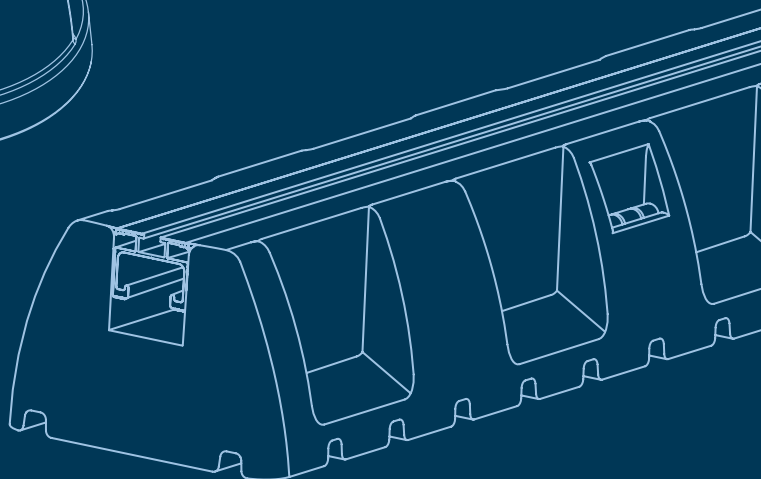

Smart Clima

Accessories for Air Conditioning

RUBBER DAMPERS FEET

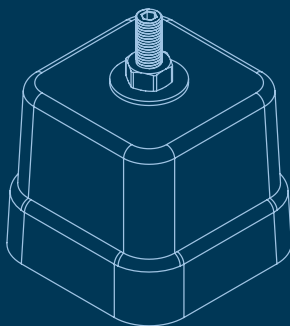
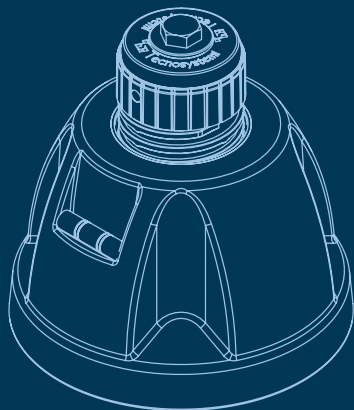



SMALL SOLUTIONS FOR BIG RESULTS

The "Zeus" floor support is made of vulcanised SBR rubber. Manufactured in two versions with a fixed height and with a height-adjustable ring nut, they are suitable for all types of underfloor air conditioners or boilers.

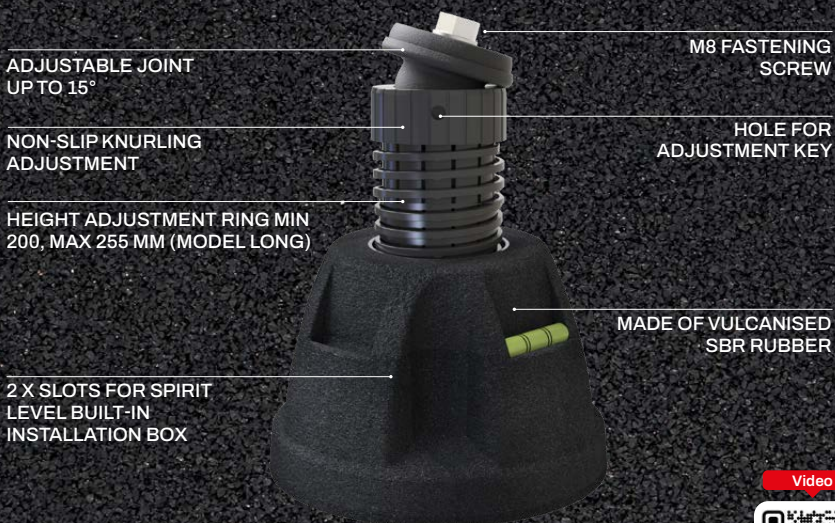

Video



ZEUS

ANTI-VIBRATION FOOT IN VULCANISED RUBBER SBR

- Made of SBR recycled volcanic rubber
- Height 107mm
- No. 2 seats for spirit level insertion
- Fixing screw M8



MADE IN ITALY

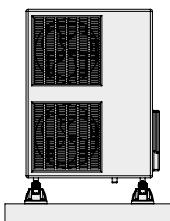

ZEUS R

ADJUSTABLE VIBRATION DAMPENING FOOT IN SBR VULCANISED RUBBER

- Anti-vibration device included
- Made of SBR recycled volcanic rubber
- Height adjustable from 130 - 150 mm
- Non-slip knurling adjustment

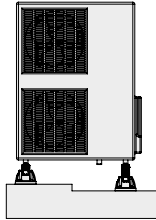

ZEUS HIGH ARTICULATED

ANTI-VIBRATION FOOT IN VULCANISED RUBBER SBR

- Anti-vibration device included
- Made of SBR recycled volcanic rubber
- Height adjustment ring nut min 150 max 205 mm (model Short)
- Height adjustment ring nut min 200 max 255 mm (model Long)
- Non-slip knurling adjustment
- Adjustable Joint
- No. 2 seats for spirit level insertion
- Fixing screw M8 x 50
- Inclination 0-15°

MADE IN ITALY

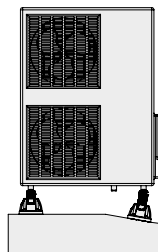



ZEUS

SPK NATURALLY RESISTANT!



SPK

SBR VULCANISED RUBBER FLOOR SUPPORT

- Made of vulcanised natural rubber
- Fastening bracket hardware supplied
- Recommended for VRV - VRF



MADE IN ITALY



SPK-M

SBR VULCANISED RUBBER FLOOR SUPPORT WITH THREADED ROD

- Made of vulcanised natural rubber
- M8 threaded rod included
- M8 washer and bolt included



MADE IN ITALY



EXTREME VIBRATION-DAMPING FLOOR BASE



The “EXTREME” vibration-damping floor base is with a characteristic vulcanised recycled rubber granule structure and is equipped with an aluminium profile useful for attaching the outdoor condensing unit to the support itself. The floor base can be used to support external condensing units, VRV-VRF, base boilers, electrical ducts or pipes.

The floor base is equipped with a built-in levelling device for correct positioning and can be fixed to the ground. The machines are fixed to the base with nut and M8 screw or through the supplied sliders with M8 screw.



U-PROFILE: L.38 x H.31 mm
Embedded for strong tightness

ALUMINIUM PROFILE FIXING
WITH M8 NUT AND BOLT
OR WITH THREADED PLATE

GROOVED SUPPORT BASE
NON-SLIP WATER DRAIN

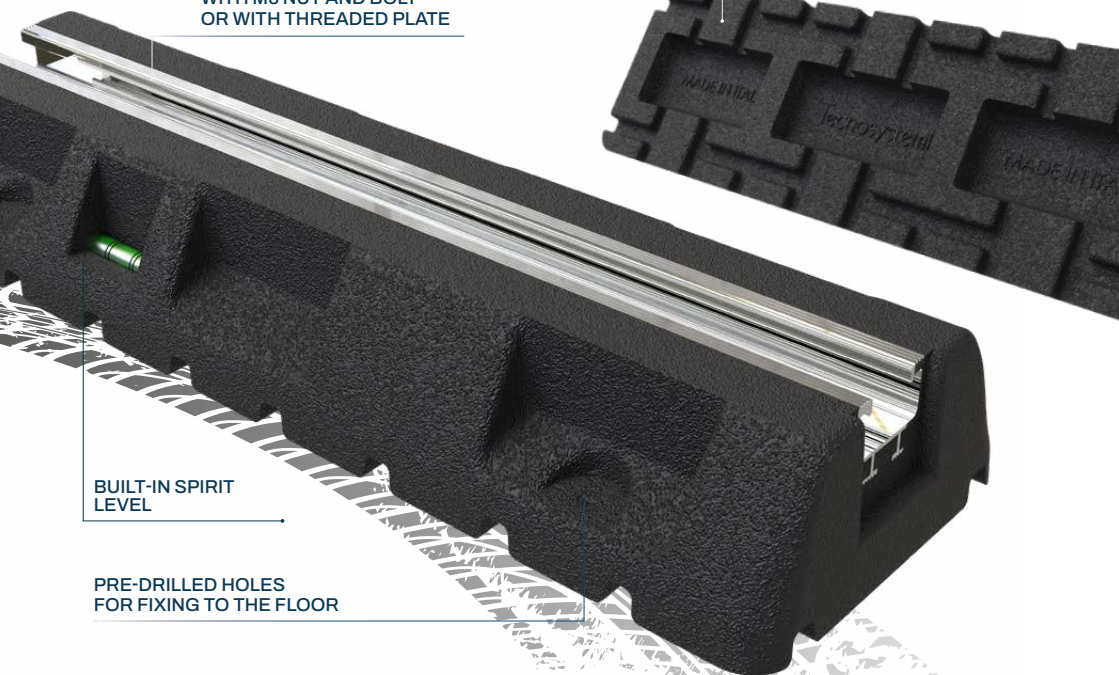

BUILT-IN SPIRIT
LEVEL

PRE-DRILLED HOLES
FOR FIXING TO THE FLOOR

3 PCS EXTREME 100 - 8

VULCANISED RUBBER
VIBRATION-RESISTANT FLOOR BASE

MADE IN ITALY



Complete with nut,
washer and M8 bolt

U-profile:
L. 38 x H.31 mm
Embedded for
strong tightness



3 PCS EXTREME 100 - 20

VULCANISED RUBBER
VIBRATION-RESISTANT FLOOR BASE

MADE IN ITALY



Complete with threaded
plate, washer and M8 bolt

U-profile:
L. 38 x H.31 mm
Embedded for
strong tightness



EXTREME 100 - 8

VULCANISED RUBBER
VIBRATION-RESISTANT FLOOR BASE

MADE IN ITALY



Complete with nut,
washer and M8 bolt

U-profile:
L. 38 x H.31 mm
Embedded for
strong tightness



EXTREME 70 - 8

MADE IN ITALY



VULCANISED RUBBER VIBRATION-RESISTANT FLOOR BASE



Complete with nut,
washer and M8 bolt

U-profile:
L. 38 x H.31 mm
Embedded for
strong tightness



EXTREME 100 - 20

MADE IN ITALY



VULCANISED RUBBER VIBRATION-RESISTANT FLOOR BASE



Complete with threaded
plate, washer and M8 bolt

U-profile:
L. 38 x H.31 mm
Embedded for
strong tightness



EXTREME 70 - 20

MADE IN ITALY



VULCANISED RUBBER VIBRATION-RESISTANT FLOOR BASE



Complete with threaded
plate, washer and M8 bolt

U-profile:
L. 38 x H.31 mm
Embedded for
strong tightness



EXTREME 100 - A

VULCANISED RUBBER
VIBRATION-RESISTANT FLOOR BASE

MADE IN ITALY



Fixing the direct screw on support



Supplied with self-tapping screws

EXTREME 70 - A

VULCANISED RUBBER
VIBRATION-RESISTANT FLOOR BASE

MADE IN ITALY



Fixing the direct screw on support



Supplied with self-tapping screws

EXTREME HEIGHT 100

RAISER FOR FLOOR BASE WITH VIBRATION
DAMPING IN VULCANISED RUBBER SBR

MADE IN ITALY

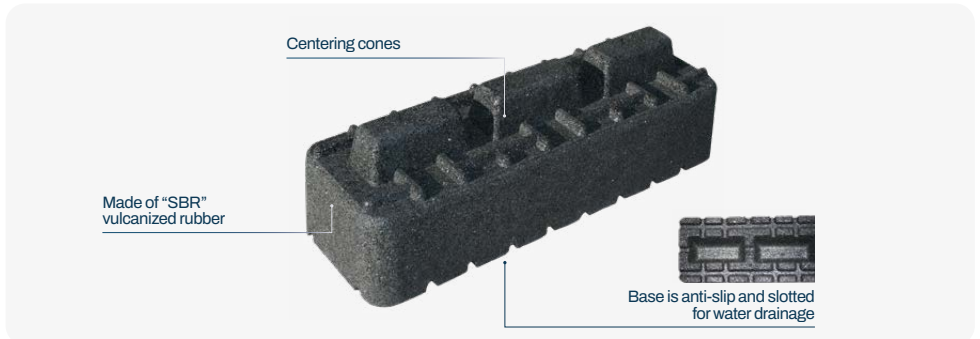



A NEW RIDE FOR WORN TYRES

A VIRTUOSITY RESULTING
FROM THE RESEARCH AND PLANNING
OF OUR **CIRCULAR ECONOMY**

Tecosystemi S.p.A. Società Benefit

PLANT 1 – Via dell'Industria, 2/4 | PLANT 2 – Via Caduti del Lavoro, 7 | PLANT 3 – Via Caduti del Lavoro, 5

Z.i. San Giacomo di Veglia - 31029 Vittorio Veneto (TV)

Tel. +39 0438.500044 | info@tecosystemi.com | www.tecosystemi.com

C.F. - P.IVA - R.I. TV IT02535780247 - Cap. Soc. € 5.000.000,00 i.v.

