

# DATASHEET

rev. 01 - 28/11/2022

CE

Brass body high pressure regulator from 6 to 12 kg/h with variable calibration and pressure gauge

21000160



## TECHNICAL SPECIFICATIONS:

- Capacity from 6 to 12 kg/h
- Calibration from 0 to 4 bar
- Pressure gauge supplied
- Pressure regulator for butane gas, propane gas and mixtures thereof.
- Flow rate: 12 kg/h
- Operating pressure: adjustable 0÷4 bar or Fixed Calibration
- Feed pressure: max 16 bar
- Operating temperature:  $-20^{\circ}\text{C} \div +50^{\circ}\text{C}$
- Inlet: Female thread G 1/4"
- Output: Female thread G 1/4"
- Product in accordance with standard EN 16129

## PRESSURE DIAGRAM

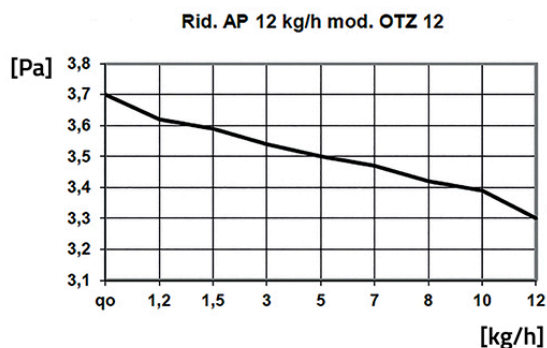

## MATERIALS

- Brass body
- Zamak cover
- Lid is protected with nickel plating.
- NBR rubber membrane according to Standard EN 549, reinforced with cloth.
- Other NBR rubber components according to EN 549.

## TECHNICAL DRAWING

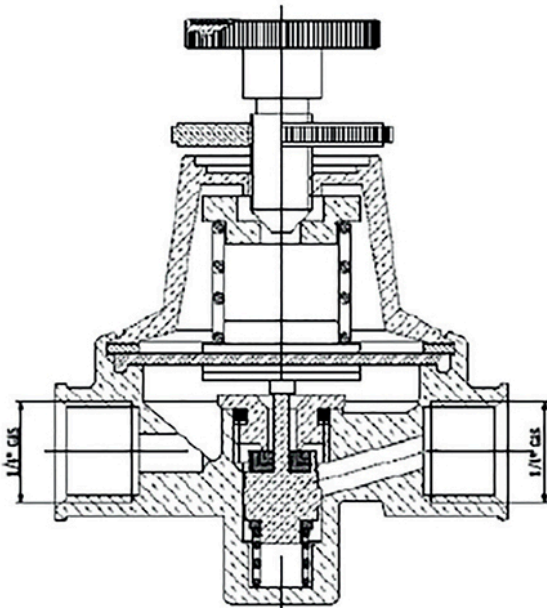

## USE

- The regulator is to be used as 1st stage
- The regulator is already prepared for or equipped with a pressure gauge for the output pressure reading
- For calibration adjustment, use only the supplied adjustment handwheel
- DO NOT use adjustment handwheels other than those supplied.

## INSTRUCTIONS FOR ASSEMBLY

The regulator has to be installed by checking (see arrow) the flow direction.

It is important to check before commissioning the system that the piping has been cleaned of any residue (welding, filings, etc.) that could damage the internal mechanism.

Also check that there is no water in the tank or system.

Checking for leaks (in joints) must only be carried out with specific preparations (foam canisters).

Do not use flames!

Make sure that the vent hole of the lid is always clean and free.

If the regulator had a hose connector outlet, it is imperative to secure the rubber hose using suitable hose clamps.

Also check the integrity of the pipe, the expiry date and that, after assembly, there are no kinks or abnormal bends.

Installation with the membrane plane perpendicular to the ground is recommended to avoid any condensation in the regulator.

If the regulator is equipped with a Safety Valve, it is advisable to mount it with the same facing the soil to avoid the formation of condensation.

## CALIBRATION

The regulator comes with adjusting screw and locking nut

Screw the nut onto the adjustment handwheel.

Screw the adjustment wheel into the threaded hole on the gear reducer lid until the desired pressure is reached.

N.B. Do not exceed the pressures indicated on the regulator!

Do not use the regulator for pressures other than those indicated.

The declared calibration and sealing are checked during production.

The diameter of the piping between the regulator and the operating systems must be adequately proportioned to their length to ensure the required flow rate. (See loss of load of the piping).

## TECHNICAL DATA

CODE	COUPLER INLET	COUPLER OUTLET
21000160	ITALY NUT W 20 x 14 LH	F 1/4"

## ITEMS

CODE	DESCRIPTION
21000160	VARIABLE SETTING HIGH PRESSURE REGULATOR 6-12KG/H BRASS BODY W PRESSURE GAUGE