

# DATASHEET

rev. 01 - 28/11/2022

CE

High pressure regulator 25 kg/h brass body with variable calibration with pressure gauge and safety valve

21000200



## TECHNICAL SPECIFICATIONS:

- Brass body and cover
- Capacity 25 kg/h
- Calibration from 0 to 3 bar
- Pressure gauge and safety valve supplied
- Production calibration: 1.5 bar or fixed calibration
- Safety valve (if supplied): calibrated between 1.25 and 2 times the maximum operating pressure.
- Feed pressure: max 16 bar
- Operating temperature:  $-20^{\circ}\text{C} \div +50^{\circ}\text{C}$
- Inlet: Female thread G 1/4" (or twist cylinder fitting)
- Output: Female thread G 3/8"
- Product in accordance with standard EN 16129

## OPERATING SPECIFICATIONS

Guaranteed load capacity (Mg): 12 kg/h

Feed pressure (P):

- P<sub>dmax</sub> +0.2÷7.5 bar (butane)
- P<sub>dmax</sub> +0.5÷16 bar (propane)
- P<sub>dmax</sub> +0.2÷16 bar (LPG)

Nominal output pressure (P<sub>d</sub>): 0 ÷ 4 bar

Operating temperature:

- Min.  $-20^{\circ}\text{C} \div$  Max.  $+50^{\circ}\text{C}$  (propane and LPG)
- Min.  $0^{\circ}\text{C} \div$  Max.  $+50^{\circ}\text{C}$  (butane)

Suitable for use with: Butane - Propane - LPG

## MATERIALS

- Body: Brass CW 617 N Standard EN 12165
- Lid: Zama (ZL5) according to EN 1774 and protected with nickel plating
- NBR rubber membrane according to Standard EN 549
- Nut: Brass CW 617 N Standard EN 12165 or in steel AVP

## TECHNICAL DRAWING

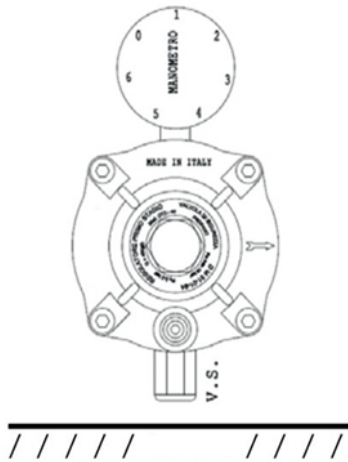

## PRESSURE DIAGRAM

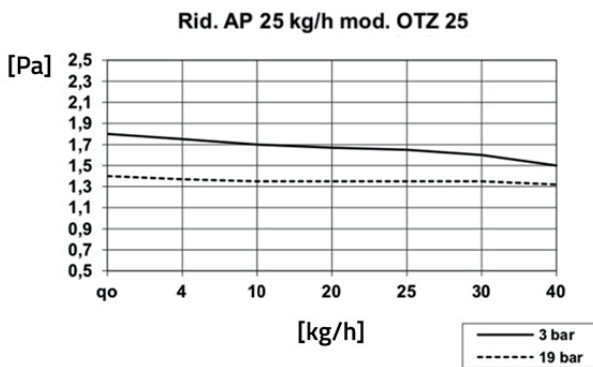

## USE

- The regulator is to be used as 1st stage
  - The regulator is already prepared for or equipped with a pressure gauge for the output pressure reading
- The reduction gears **MUST NOT** be calibrated at a pressure higher than that of the safety valve in order to avoid intervention of the safety valve itself.

## INSTRUCTIONS FOR ASSEMBLY

The regulator has to be installed by checking (see arrow) the flow direction.

It is important to check before commissioning the system that the piping has been cleaned of any residue (welding, filings, etc.) that could damage the internal mechanism. Also check that there is no water in the tank or system.

Checking for leaks (in joints) must only be carried out with specific preparations (foam canisters).

Do not use flames!

Make sure that the vent hole of the lid is always clean and free.

If the regulator had a hose connector outlet, it is imperative to secure the rubber hose using suitable hose clamps.

Also check the integrity of the pipe, the expiry date and that, after assembly, there are no kinks or abnormal bends.

Installation with the membrane plane perpendicular to the ground is recommended to avoid any condensation in the regulator.

If the regulator is equipped with a safety valve, it is advisable to mount it with the same facing the soil to avoid the formation of condensation.

## CALIBRATION

The regulator is calibrated in production at the standard pressure of 1.5 bar and is therefore ready to use without any intervention required.

If necessary, the outlet pressure can be adjusted by acting on the adjustment screws, after loosening the nut.

To increase the output pressure, screw the screw clockwise; to decrease the pressure, unscrew counter-clockwise.

It is recommended to tighten the nut at the end of calibration.

N.B. Do not exceed the pressures indicated on the regulator!

## TECHNICAL DATA

CODE	COUPLER INLET	COUPLER OUTLET
21000200	ITALY NUT W 20 x 14 LH	F 3/8"

## NOTES

Outlet pressures can be customised on request

Do not use the regulator for pressures other than those indicated.

The declared calibration and sealing are checked during production.

The diameter of the piping between the regulator and the operating systems must be adequately proportioned to their length to ensure the required flow rate. (See loss of load of the piping).

If the regulator is to be mounted in an underground tank, it is advisable to connect the vent hole of the lid to a pipe, and to bring it to the outside to protect it from dirt and water infiltrations.

(To carry out this operation, cut the top part of the plastic vent plug and insert a pipe Ø 6 into the cap itself).

## ITEMS

CODE	DESCRIPTION
21000200	VAR SETTING HIGH PRESS REG 25KG/H BRASS W PRESS GAUGE-SAFETY VALVE W20X14-1/4